

Stanzmesser und Stanzwerkzeuge: siehe Register **Werkzeuge**
Punch knives and punching tools: refer to register **Tools**

M 1:1
Scale 1:1

	Außenkammer External profile chamber					Innenkammer Internal profile chamber					
		I				II					
verpressbar crimpable verstiftbar nailable nachträglich verklebbar retro gluing after assembly											
B 806030	Z 914240	Z 914297	2 x Z 911049	Z 911187	-	-	Z 911120	Z 911121	2 x Z 900023	Z 911187	Z 914420
B 808010	-	Z 914747	2 x Z 911049	Z 911187	-	-	Z 914750	-	2 x Z 900024	Z 911187	Z 914889 Z 914890
B 808020	-	Z 914781	2 x Z 911049	Z 911187	-	-	Z 914750	-	2 x Z 900024	Z 911187	Z 914889 Z 914890
B 806030	Z 914234 L Z 914235 R	Z 914376	2 x Z 911513	Z 911187	2 x Z 914352	-	Z 914385	-	2 x Z 914351	Z 911187	Z 914420

007000100

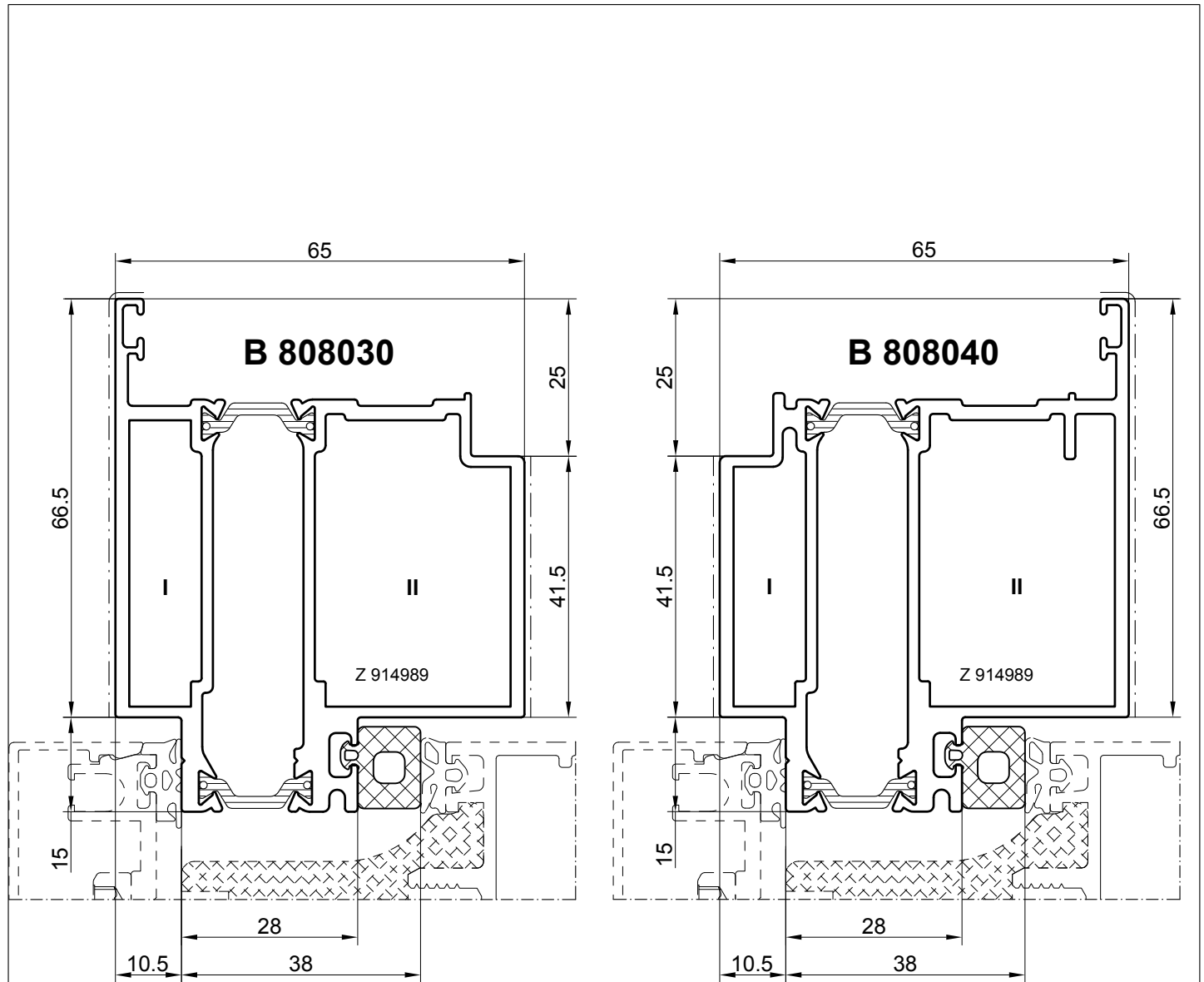
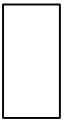

Stanzmesser und Stanzwerkzeuge: siehe Register **Werkzeuge**
Punch knives and punching tools: refer to register **Tools**

M 1:1
Scale 1:1

	Außenkammer External profile chamber					Innenkammer Internal profile chamber					
		I					II				
<ul style="list-style-type: none"> verpressbar crimpable verstiftbar nailable nachträglich verklebbar retro gluing after assembly 											
B 808030	-	Z 914747	2 x Z 911049	Z 911187	-	-	Z 914750	-	2 x Z 900024	Z 911187	Z 914889
B 808040	-	Z 914781	2 x Z 911049	Z 911187	-	-	Z 914750	-	2 x Z 900024	Z 911187	Z 914889

006000200