

Bearbeitungsschritte

Dichtung umlaufend einziehen, Stoß oben mittig

Processing steps

Draw gasket in continuously, joint in upper central area



Z 994452



Z 903941

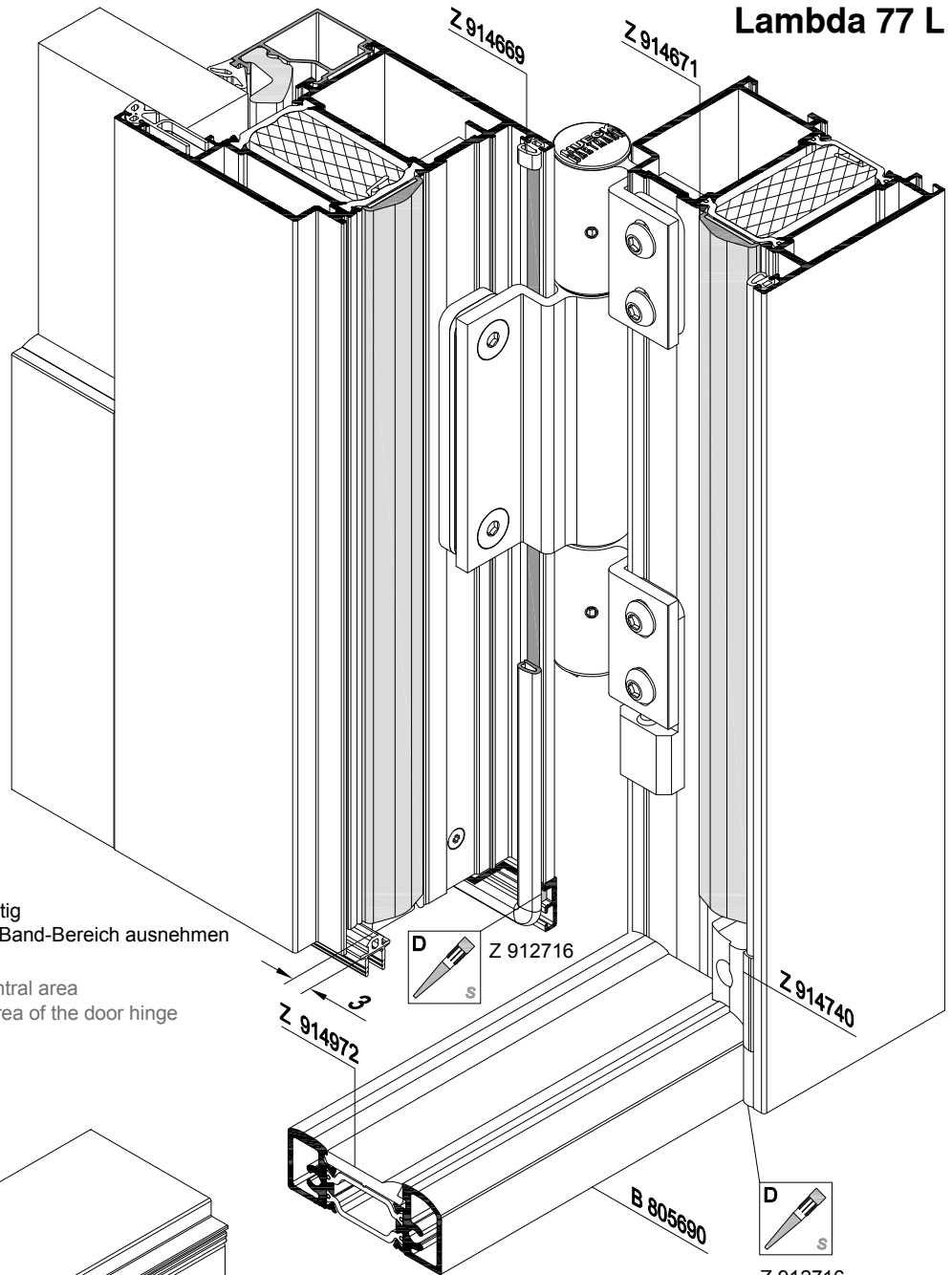

Bearbeitungsschritte

1. Dichtung umlaufend einziehen, Stoß oben mittig
2. Beschlagteile anschlagen, Dichtungslippe im Band-Bereich ausnehmen

Processing steps

1. Draw gasket in continuously, joint in upper central area
2. Attach fitting parts, remove gasket lip in the area of the door hinge

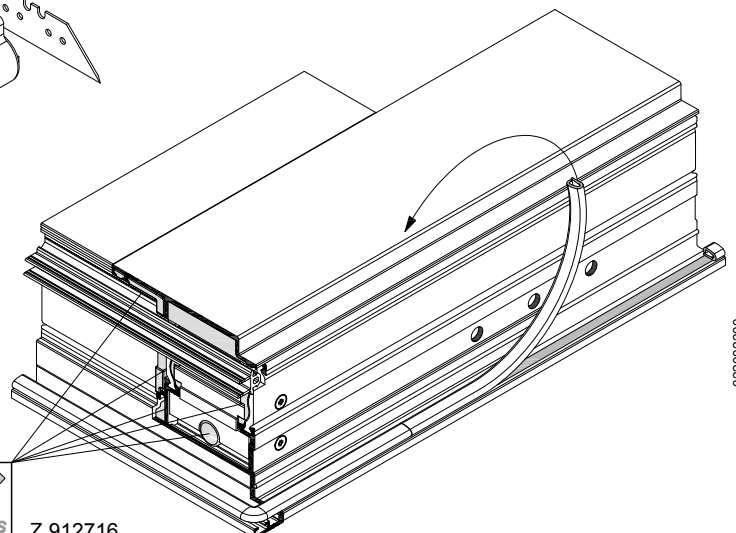
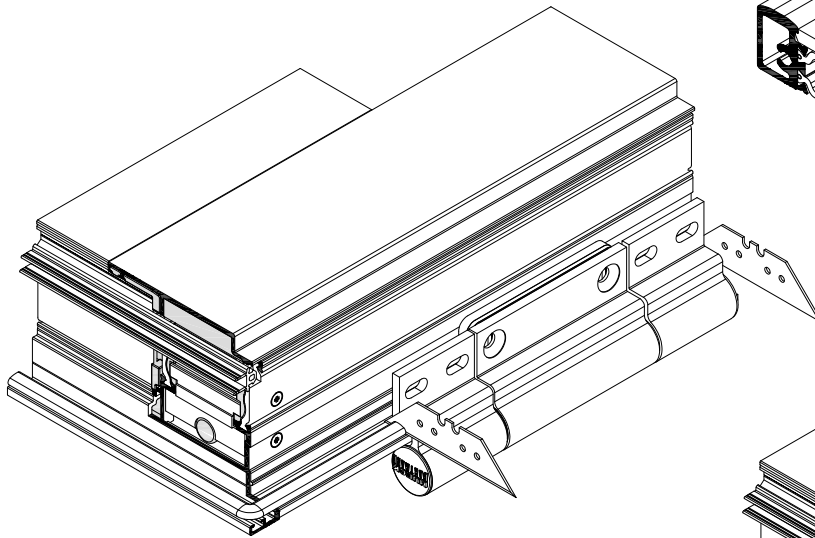

022002200