

	Außenkammer External profile chamber					Innenkammer Internal profile chamber					
		I					II				
verpressbar crimpable	verstiftbar nailable	nachträglich verklebbar retro gluing after assembly									
<b>B 806000</b>	Z 914240	Z 914294	2 x Z 914864	Z 911187		-	Z 911486	Z 911488	2 x Z 900023	Z 911187	Z 914709
<b>B 806010</b>	Z 914240	Z 914295	2 x Z 911049	Z 911187		-	Z 911956	Z 912316	2 x Z 900023	Z 911187	Z 914709
<b>B 806020</b>	Z 914240	Z 914296	2 x Z 911049	Z 911187		-	Z 911027	Z 911030	2 x Z 900023	Z 911187	Z 914709
<b>B 806030</b>	Z 914240	Z 914297	2 x Z 911049	Z 911187		-	Z 911120	Z 911121	2 x Z 900023	Z 911187	Z 914709
<b>B 806000</b>	Z 914234 L Z 914235 R	Z 914373	2 x Z 911513	Z 911187	Z 917305	-	Z 914382	-	2 x Z 914351	Z 911187	Z 914709
<b>B 806010</b>	Z 914234 L Z 914235 R	Z 914374	2 x Z 911513	Z 911187	Z 917306	-	Z 914383	-	2 x Z 914351	Z 911187	Z 914709
<b>B 806020</b>	Z 914234 L Z 914235 R	Z 914375	2 x Z 911513	Z 911187	Z 917307	-	Z 914384	-	2 x Z 914351	Z 911187	Z 914709
<b>B 806030</b>	Z 914234 L Z 914235 R	Z 914376	2 x Z 911513	Z 911187	Z 917308	-	Z 914385	-	2 x Z 914351	Z 911187	Z 914709

009000500

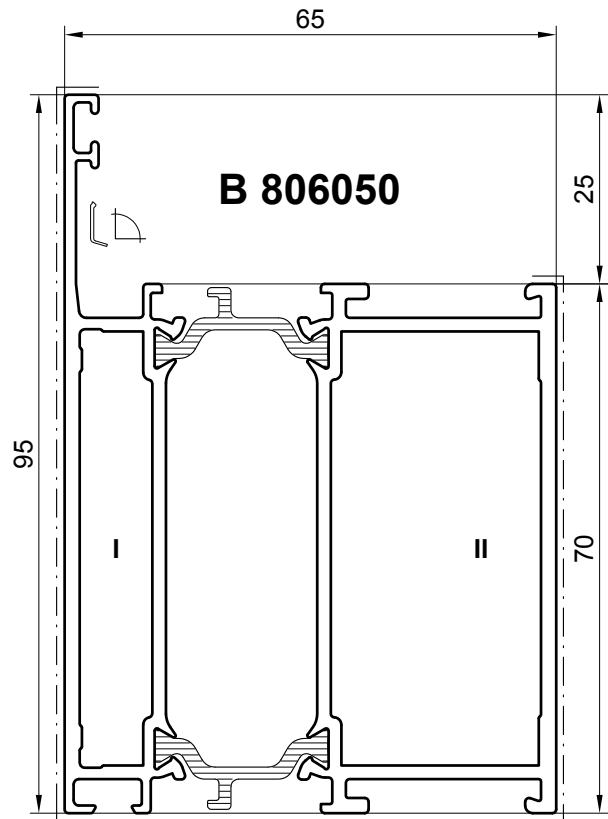
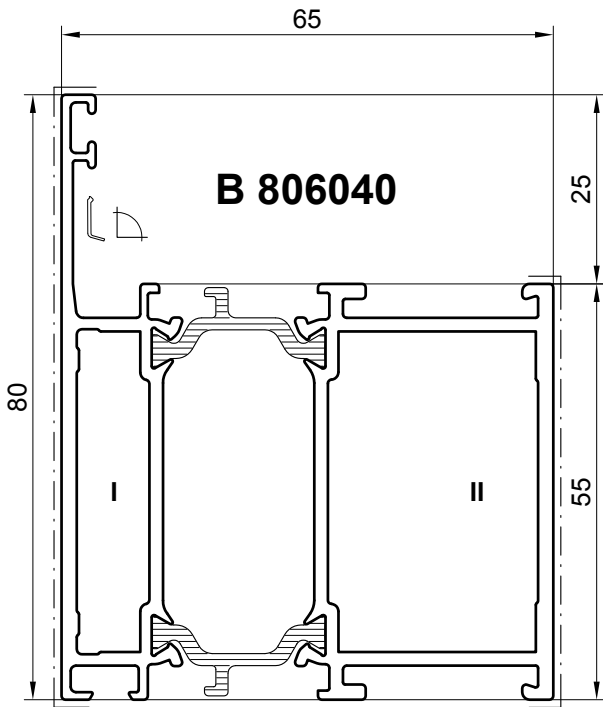
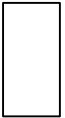

Bei Verwendung des 160kg DK-Beschlages sind bandseitig verstärkte Eckwinkel erforderlich.

**Siehe Register Beschläge**

If the 160 kg turn-tilt fitting is used, reinforced corner brackets are required on the hinge side.

See register Fittings

Stanzmesser und Stanzwerkzeuge: siehe Register **Werkzeuge**

Punch knives and punching tools: refer to register **Tools**

M 1:1  
Scale 1:1

\* = Nicht nachträglich verklebbar  
\* = No retro gluing after assembly

 verpressbar crimpable verstiftbar nailable nachträglich verklebbar retro gluing after assembly	Außenkammer External profile chamber					Innenkammer Internal profile chamber					
	I					II					
					-	-					
<b>B 806040</b>	Z 914240	Z 914298*	2 x Z 911049	Z 911187	-	-	Z 914423	Z 914422	2 x Z 900023	Z 911187	Z 914709
<b>B 806050</b>	Z 914240	Z 914299*	2 x Z 911049	Z 911187	-	-	Z 914425	Z 914424	2 x Z 900023	Z 911187	Z 914709
<b>B 806040</b>	Z 914234 L Z 914235 R	Z 914377	2 x Z 911049	Z 911187	2 x Z 914352	-	Z 914386	-	2 x Z 914351	Z 911187	Z 914709
<b>B 806050</b>	Z 914234 L Z 914235 R	Z 914378	2 x Z 911049	Z 911187	2 x Z 914352	-	Z 914387	-	2 x Z 914351	Z 911187	Z 914709

010000800

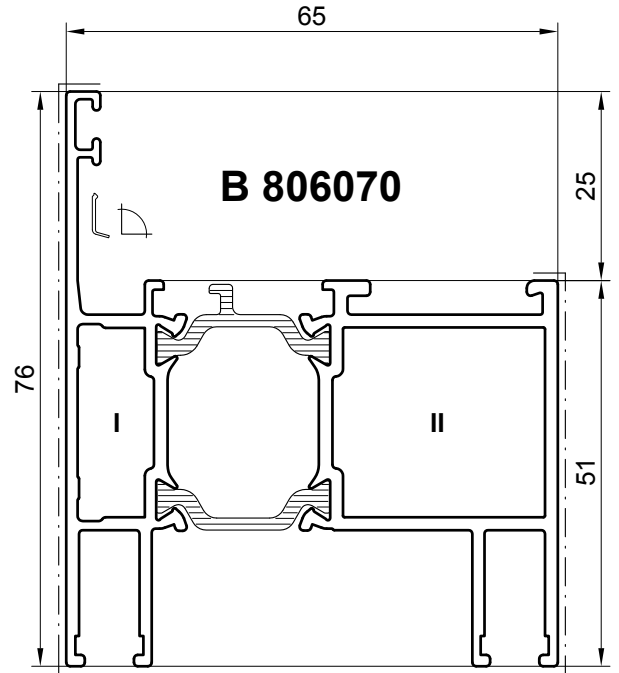
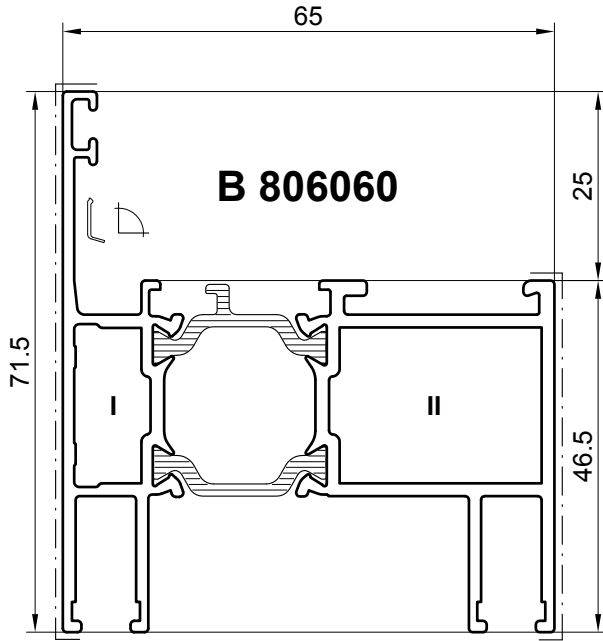

Bei Verwendung des 160kg DK-Beschlages sind bandseitig verstärkte Eckwinkel erforderlich.

**Siehe Register Beschläge**

If the 160 kg turn-tilt fitting is used, reinforced corner brackets are required on the hinge side.

**See register Fittings**

Stanzmesser und Stanzwerkzeuge: siehe Register **Werkzeuge**

Punch knives and punching tools: refer to register **Tools**

M 1:1  
Scale 1:1

\* = Nicht nachträglich verklebbar

\* = No retro gluing after assembly

	Außenkammer External profile chamber					Innenkammer Internal profile chamber					
				I					II		
<b>B 806060</b>	Z 914240	Z 914295*	2 x Z 911049	Z 911187	-	-	Z 911956	Z 912316	2 x Z 900023	Z 911187	Z 914709
<b>B 806070</b>	Z 914240	Z 914296*	2 x Z 911049	Z 911187	-	-	Z 911027	Z 911030	2 x Z 900023	Z 911187	Z 914709
<b>B 806060</b>	Z 914234 L Z 914235 R	Z 914374	2 x Z 911513	Z 911187	Z 917306	-	Z 914383	-	2 x Z 914351	Z 911187	Z 914709
<b>B 806070</b>	Z 914234 L Z 914235 R	Z 914375	2 x Z 911513	Z 911187	Z 917307	-	Z 914384	-	2 x Z 914351	Z 911187	Z 914709

011000700

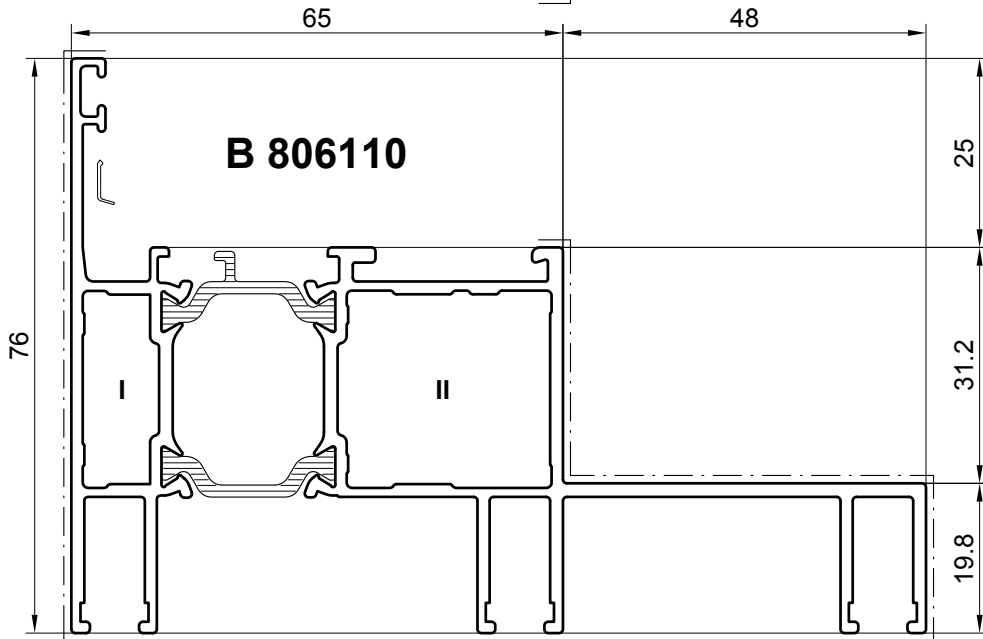
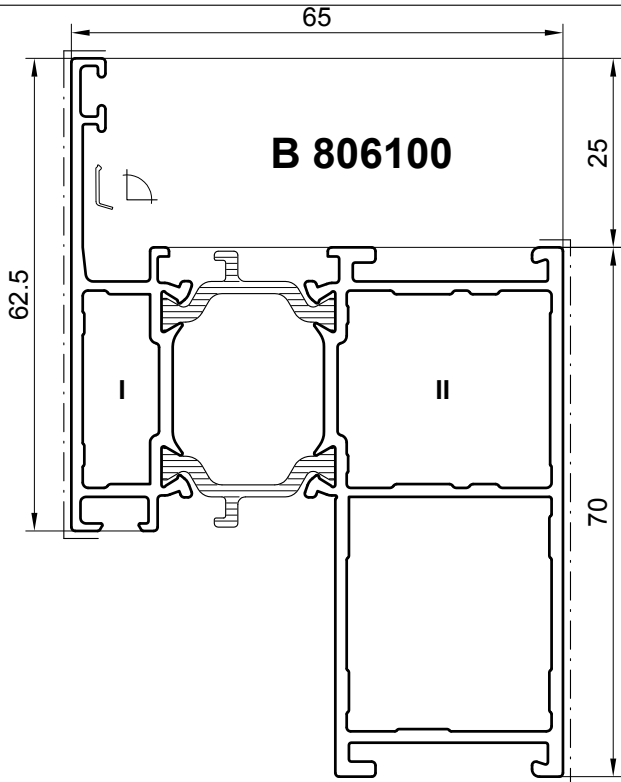

M 1:1  
Scale 1:1

Stanzmesser und Stanzwerkzeuge: siehe Register **Werkzeuge**  
Punch knives and punching tools: refer to register **Tools**

	Außenkammer External profile chamber					Innenkammer Internal profile chamber					
	I					II					
<ul style="list-style-type: none"> <li> verpressbar crimpable</li> <li> verstitfbar nailable</li> <li> nachträglich verklebbar retro gluing after assembly</li> </ul>											
<b>B 806100</b>	Z 914240	Z 914296	2 x Z 911049	Z 911187	-	-	Z 911027	-	2 x Z 900023	Z 911187	Z 914709
<b>B 806100</b>											
<b>B 806100</b>	Z 914234 L Z 914235 R	Z 914375	2 x Z 911513	Z 911187	Z 917307	-	Z 914384	-	2 x Z 914351	Z 911187	Z 914709
<b>B 806110</b>	Z 914234 L Z 914235 R	Z 914375	2 x Z 911513	Z 911187	Z 917307	-	Z 914384	-	2 x Z 914351	Z 911187	Z 914709

012006900

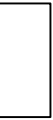

## B 806120

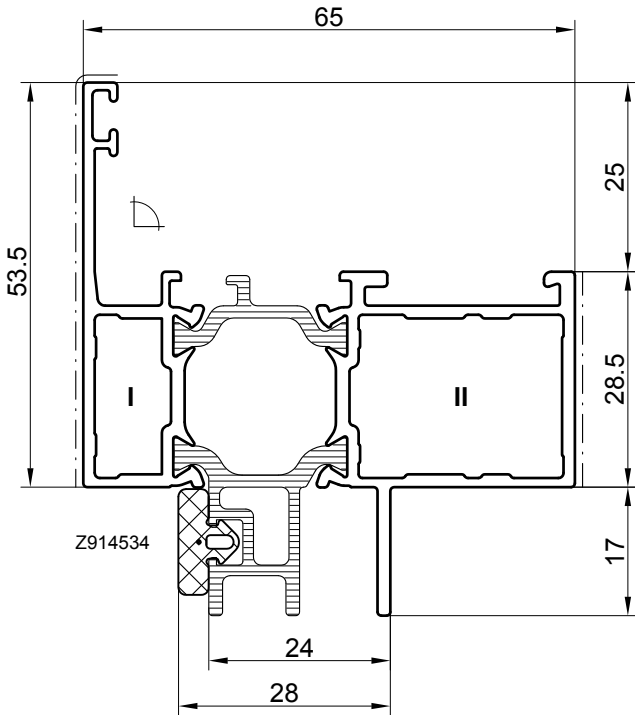

Bitte die Dichtung separat bestellen  
Please order the gasket separately

## B 806160

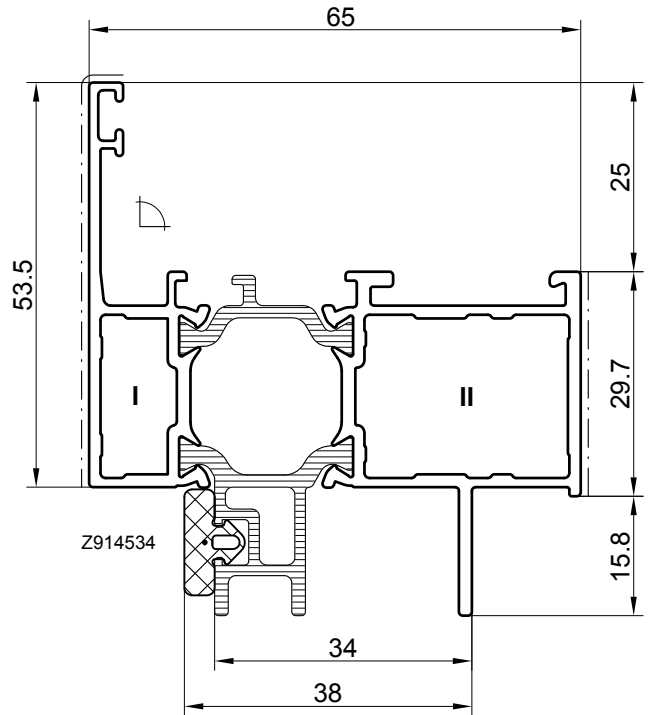

Bitte die Dichtung separat bestellen  
Please order the gasket separately











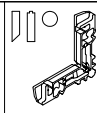

Die Dichtung kann alternativ im Blendrahmenprofil zugesägt werden  
An alternative method is to cut the profile and gasket simultaneously

Stanzmesser und Stanzwerkzeuge: siehe Register **Werkzeuge**  
Punch knives and punching tools: refer to register **Tools**

\* = nicht pressbar  
\* = not crimpable

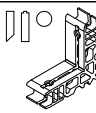
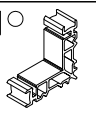
M 1:1  
Scale 1:1

01.30.03.200

	Außenkammer External profile chamber				Innenkammer Internal profile chamber						
		I				II					
<ul style="list-style-type: none"> <li> verpressbar crimpable</li> <li> verstiftbar nailable</li> <li> nachträglich verklebbar retro gluing after assembly</li> </ul>					-						
<b>B 806120</b>	Z 914240	Z 914295	2 x Z 911049	Z 911187	-	Z 911956	<b>Z 912316</b>	2 x Z 900023	Z 911187	Z 914710	Z 914710
<b>B 806160</b>	Z 914240	Z 914295	2 x Z 911049	Z 911187	-	Z 911956 *	<b>Z 912316 *</b>	2 x Z 900023	Z 911187	Z 914710	Z 914710



## B 806900

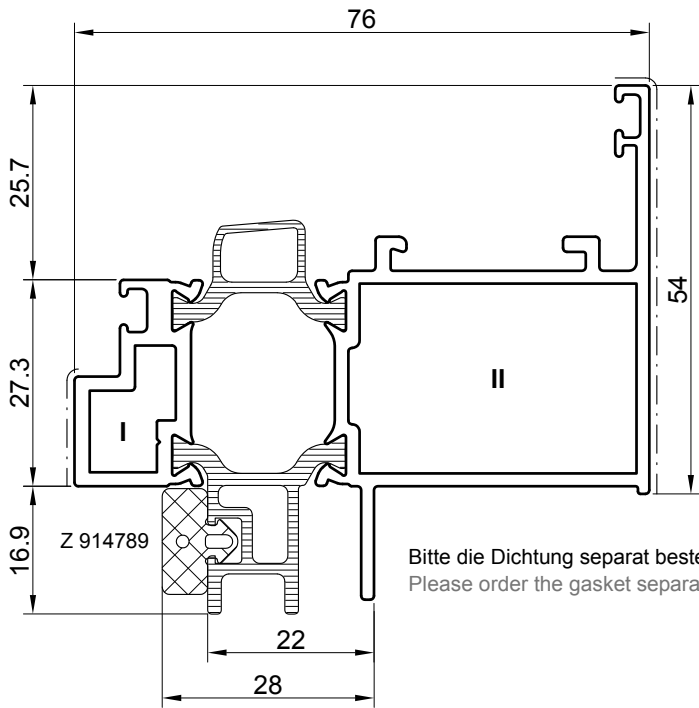

Bitte die Dichtung separat bestellen  
Please order the gasket separately

Die Dichtung kann alternativ im Blendrahmenprofil zugesägt werden  
An alternative method is to cut the profile and gasket simultaneously

\* Bei Einsatz eines Senk-Klapp Beschlages für obere Ecken erforderlich. Bitte Verarbeitungshinweise beachten!  
\* If using a top-hung projecting out window stay-arm, for upper edges required. Please refer to Processing!

Stanzmesser und Stanzwerkzeuge: siehe Register **Werkzeuge**  
Punch knives and punching tools: refer to register **Tools**

## B 806910

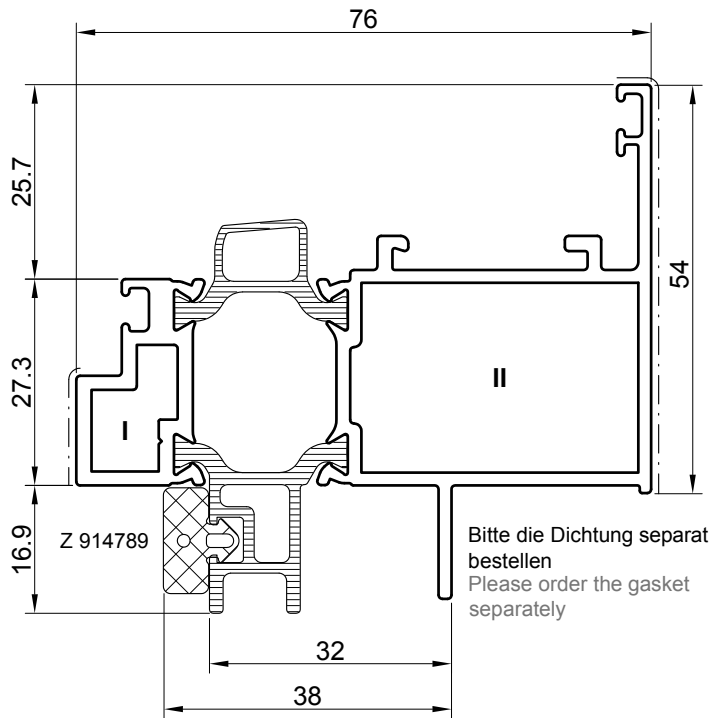

Bitte die Dichtung separat bestellen  
Please order the gasket separately

M 1:1  
Scale 1:1

	Außenkammer External profile chamber					Innenkammer Internal profile chamber					
	I	II				I	II				
verpressbar crimpable verstiftbar nailable nachträglich verklebbar retro gluing after assembly											
<b>B 806900</b>	-	Z 914571	-	-		-	Z 914790	Z 914764 Z 917153 *	2 x Z 900023	Z 911187	Z 914574
<b>B 806910</b>	-	Z 914571	-	-		-	Z 914790	Z 914764 Z 917153 *	2 x Z 900023	Z 911187	Z 914574

01407800



## P 803712

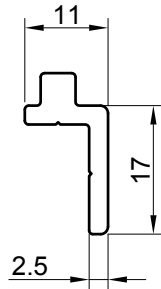

## P 806713

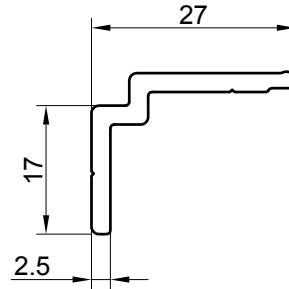

Bitte die Sägeauflage Z 917399 separat bestellen  
Please order the spacer for sawing Z 917399 separately

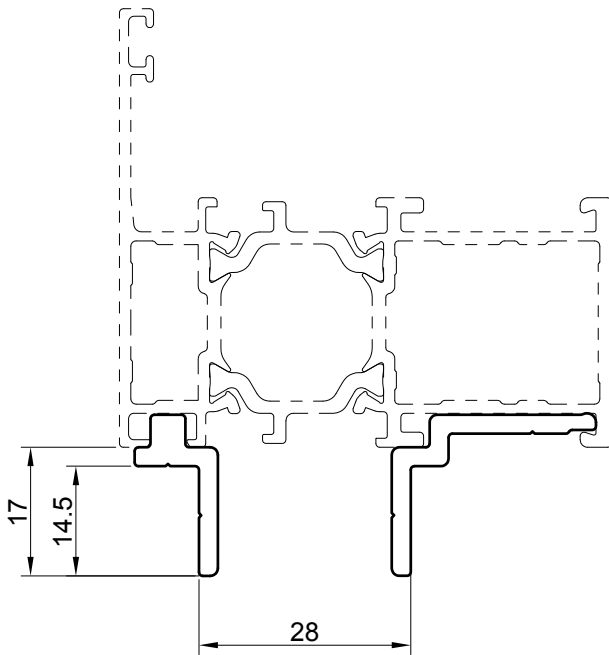
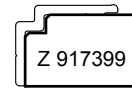

Einspannprofile sind passend für folgende Blendrahmen:  
Interlocking profiles fits to the fixed frame profiles:

- B 806000
- B 806010
- B 806020
- B 806030
- B 806040
- B 806050
- B 806140
- B 806150
- B 806170
- B 806180

01.5008000

Stanzmesser und Stanzwerkzeuge: siehe Register **Werkzeuge**  
Punch knives and punching tools: refer to register **Tools**

M 1:1  
Scale 1:1

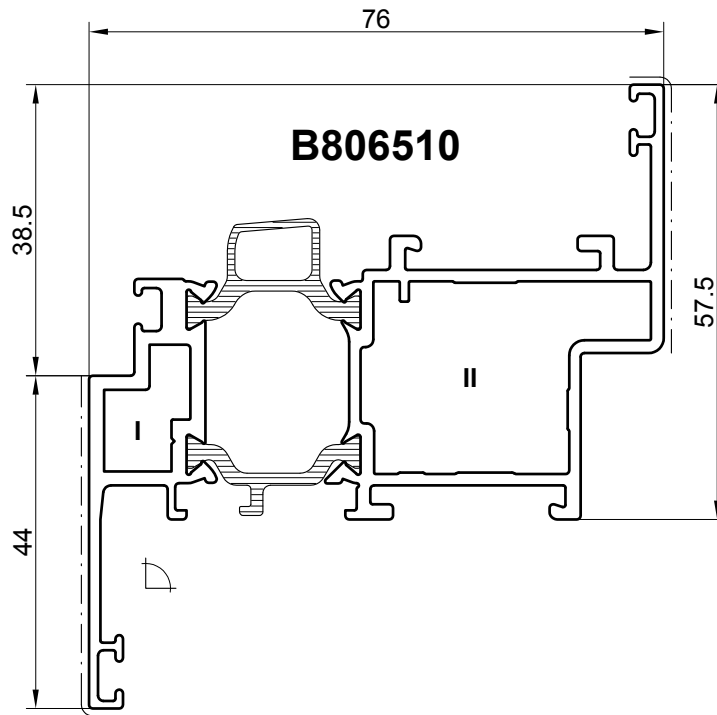
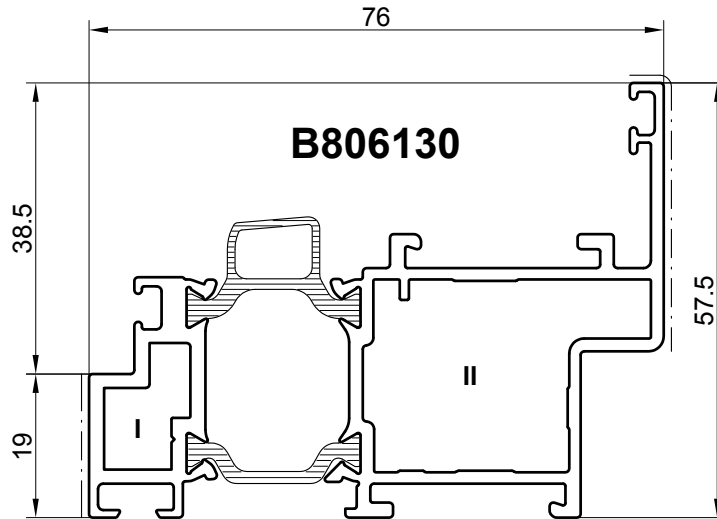
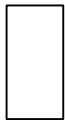

\* Bei Einsatz eines Senk-Klapp Beschlages für obere Ecken erforderlich. Bitte Verarbeitungshinweise beachten!  
 \* If using a top-hung projecting out window stay-arm, for upper edges required. Please refer to Processing!

Stanzmesser und Stanzwerkzeuge: siehe Register **Werkzeuge**  
 Punch knives and punching tools: refer to register **Tools**

M 1:1  
 Scale 1:1

	Außenkammer External profile chamber					Innenkammer Internal profile chamber					
		I					II				
◻ verpressbar crimpable ◻ verstiftbar nailable ○ nachträglich verklebbar retro gluing after assembly	◻	◻	◻	◻	◻	◻	◻	◻	◻	◻	◻
<b>B 806130</b>	-	Z 914571	-	-	-	-	Z 914569	Z 914713 Z 914570 *	2 x Z 900023	Z 911187	Z 914709
<b>B 806510</b>	Z 914240	Z 914571	-	-	-	-	Z 914569	Z 914713 Z 914570 *	2 x Z 900023	Z 911187	Z 914709

016005400

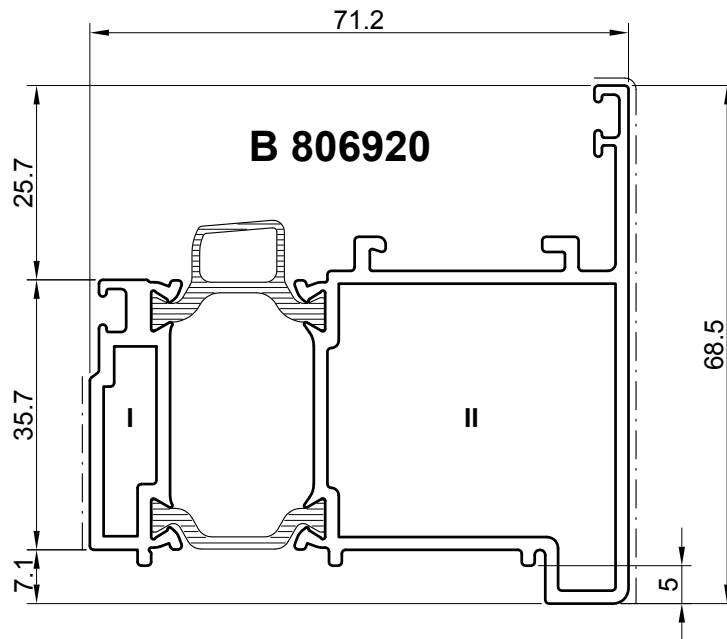
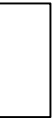

\* Bei Einsatz eines Senk-Klapp Beschlages für obere Ecken erforderlich. Bitte Verarbeitungshinweise beachten!  
 \* If using a top-hung projecting out window stay-arm, for upper edges required. Please refer to Processing!

Stanzmesser und Stanzwerkzeuge: siehe Register **Werkzeuge**  
 Punch knives and punching tools: refer to register **Tools**

M 1:1  
 Scale 1:1

017007700

	Außenkammer External profile chamber					Innenkammer Internal profile chamber					
	I					II					
<b>B 806920</b>	-	Z 914954	-	-	-	-	Z 914952	Z 914953 Z 917154 *	2 x Z 900023	Z 911187	Z 914574

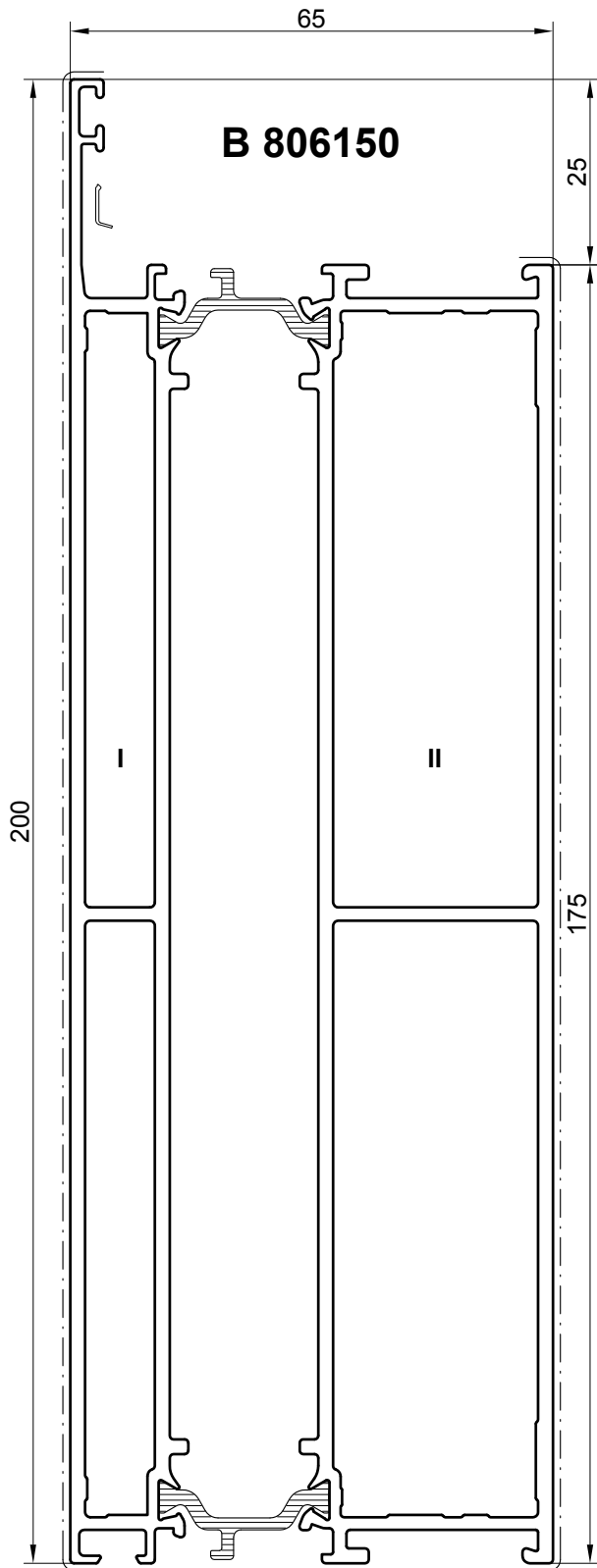
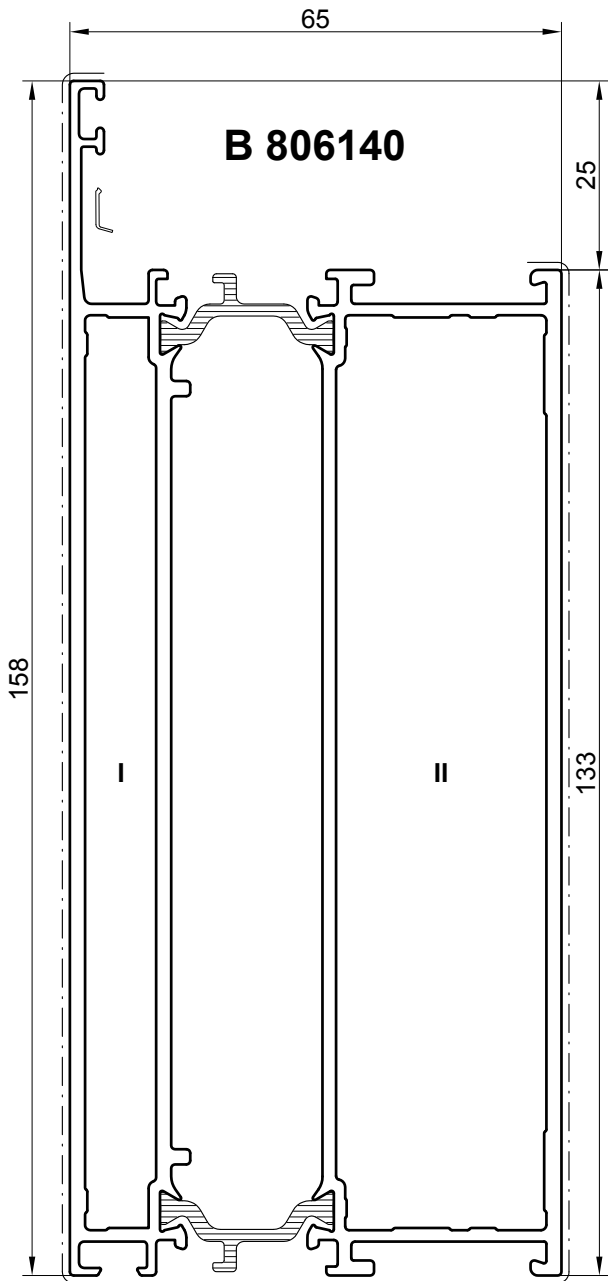

Stanzmesser und Stanzwerkzeuge: siehe Register **Werkzeuge**  
Punch knives and punching tools: refer to register **Tools**

M 1:1  
Scale 1:1

	Außenkammer External profile chamber					Innenkammer Internal profile chamber				
	I					II				
<b>B 806140</b>	Z 914234 L Z 914235 R	Z 914719	2 x Z 911513	Z 911187	2 x Z 914352	-	Z 914720		2 x Z 914351	Z 911187 Z 914709
<b>B 806150</b>	Z 914234 L Z 914235 R	Z 914721	2 x Z 911513	Z 911187	2 x Z 914352	-	Z 914722		2 x Z 914351	Z 911187 Z 914709

018007201

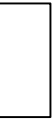

## B 806170

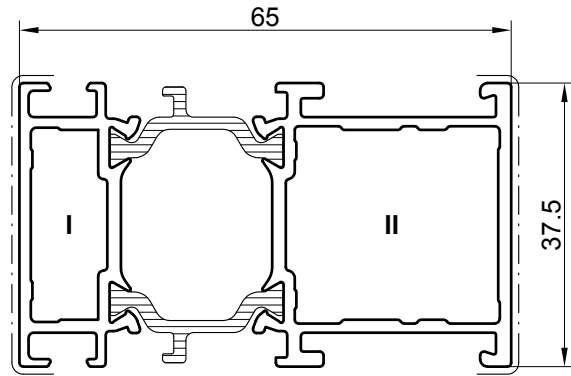

## P 803711

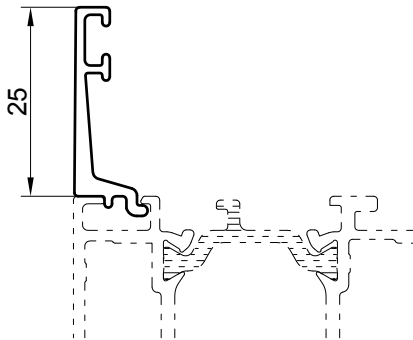



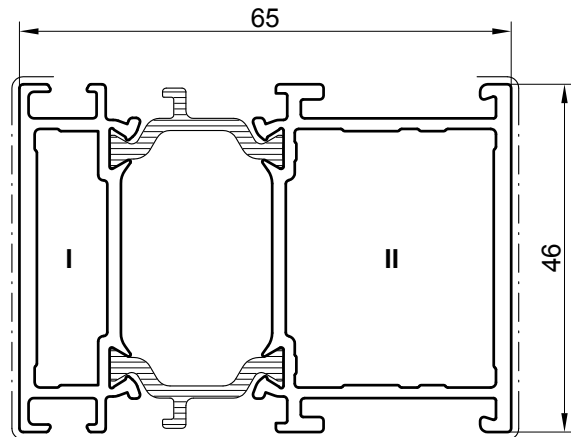











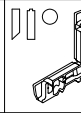



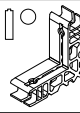
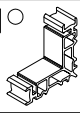

## B 806180

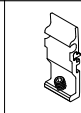

Siehe Register **Zusatzprofile**  
Refer to register **Supplementary profiles**

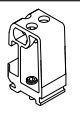
Stanzmesser und Stanzwerkzeuge: siehe Register **Werkzeuge**  
Punch knives and punching tools: refer to register **Tools**

M 1:1  
Scale 1:1

	Außenkammer External profile chamber					Innenkammer Internal profile chamber					
		I				II					
<ul style="list-style-type: none"> <li> verpressbar crimpable</li> <li> verstiftbar nailable</li> <li> nachträglich verklebbar retro gluing after assembly</li> </ul>											
<b>B 806170</b>	-	Z 914296	2 x Z 911049	Z 911187		-	Z 911027	Z 911030	2 x Z 900023	Z 911187	Z 914710
<b>B 806180</b>	-	Z 914297	2 x Z 911049	Z 911187		-	Z 911120	Z 911121	2 x Z 900023	Z 911187	Z 914710
								-			
<b>B 806170</b>	-	Z 914375	2 x Z 911513	Z 911187	Z 917307	-	Z 914384	-	2 x Z 914351	Z 911187	Z 914710
<b>B 806180</b>	-	Z 914376	2 x Z 911513	Z 911187	Z 917308	-	Z 914385	-	2 x Z 914351	Z 911187	Z 914710

019007300