

Bei Verwendung des 160kg DK-Beschlages sind bandseitig verstärkte Eckwinkel erforderlich.
Siehe Register Beschläge
 If the 160 kg turn-tilt fitting is used, reinforced corner brackets are required on the hinge side.
See register Fittings

Stanzmesser und Stanzwerkzeuge: siehe Register **Werkzeuge**
 Punch knives and punching tools: refer to register **Tools**
M 1:1
 Scale 1:1

	Außenkammer External profile chamber					Innenkammer Internal profile chamber					
				I	II				I	II	
B 803000	Z 914240	Z 914294	2 x Z 914864	Z 911187		-	Z 911486	Z 911488	2 x Z 900023	Z 911187	Z 914710
B 803010	Z 914240	Z 914295	2 x Z 911049	Z 911187		-	Z 911956	Z 912316	2 x Z 900023	Z 911187	Z 914710
B 803020	Z 914240	Z 914296	2 x Z 911049	Z 911187		-	Z 911027	Z 911030	2 x Z 900023	Z 911187	Z 914710
B 803030	Z 914240	Z 914297	2 x Z 911049	Z 911187		-	Z 911120	Z 911121	2 x Z 900023	Z 911187	Z 914710
B 803000	Z 914234 L Z 914235 R	Z 914373	2 x Z 911513	Z 911187	Z 917300	-	Z 914382	-	2 x Z 914351	Z 911187	Z 914710
B 803010	Z 914234 L Z 914235 R	Z 914374	2 x Z 911513	Z 911187	Z 917301	-	Z 914383	-	2 x Z 914351	Z 911187	Z 914710
B 803020	Z 914234 L Z 914235 R	Z 914375	2 x Z 911513	Z 911187	Z 917302	-	Z 914384	-	2 x Z 914351	Z 911187	Z 914710
B 803030	Z 914234 L Z 914235 R	Z 914376	2 x Z 911513	Z 911187	Z 917303	-	Z 914385	-	2 x Z 914351	Z 911187	Z 914710

015000700

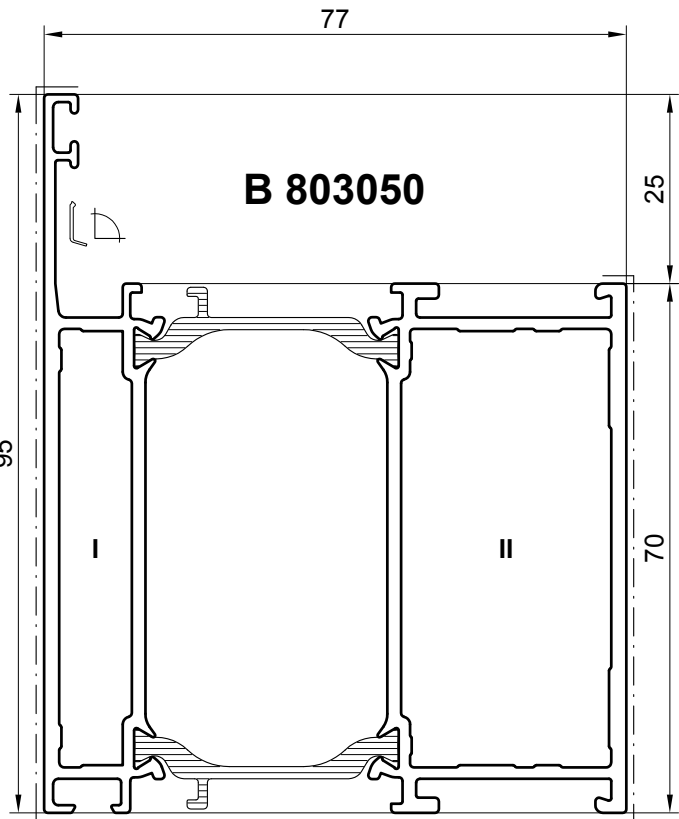
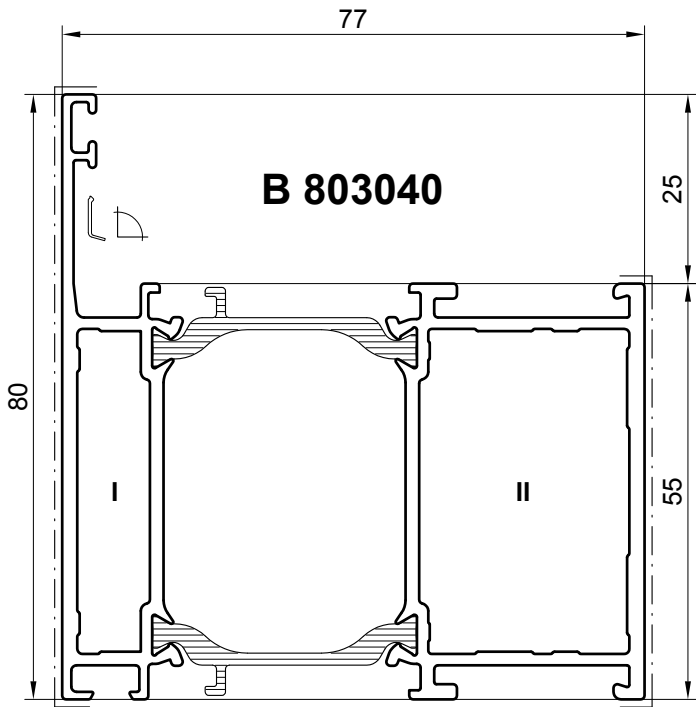

Bei Verwendung des 160kg DK-Beschlages sind bandseitig verstärkte Eckwinkel erforderlich.
Siehe Register Beschläge

If the 160 kg turn-tilt fitting is used, reinforced corner brackets are required on the hinge side.
See register Fittings

Stanzmesser und Stanzwerkzeuge: siehe Register **Werkzeuge**
Punch knives and punching tools: refer to register **Tools**

M 1:1
Scale 1:1

	Außenkammer External profile chamber					Innenkammer Internal profile chamber					
	I	II				II					
<ul style="list-style-type: none"> verpressbar crimpable verstitfbar nailable nachträglich verklebbar retro gluing after assembly 											
B 803040	Z 914240	Z 914298	2 x Z 911049	Z 911187	-	-	Z 914423	Z 914422	2 x Z 900023	Z 911187	Z 914710
B 803050	Z 914240	Z 914299	2 x Z 911049	Z 911187	-	-	Z 914425	Z 914424	2 x Z 900023	Z 911187	Z 914710
B 803040	Z 914234 L Z 914235 R	Z 914377	2 x Z 911513	Z 911187	2 x Z 914289	-	Z 914386	-	2 x Z 914351	Z 911187	Z 914710
B 803050	Z 914234 L Z 914235 R	Z 914378	2 x Z 911513	Z 911187	2 x Z 914289	-	Z 914387	-	2 x Z 914351	Z 911187	Z 914710

016000800

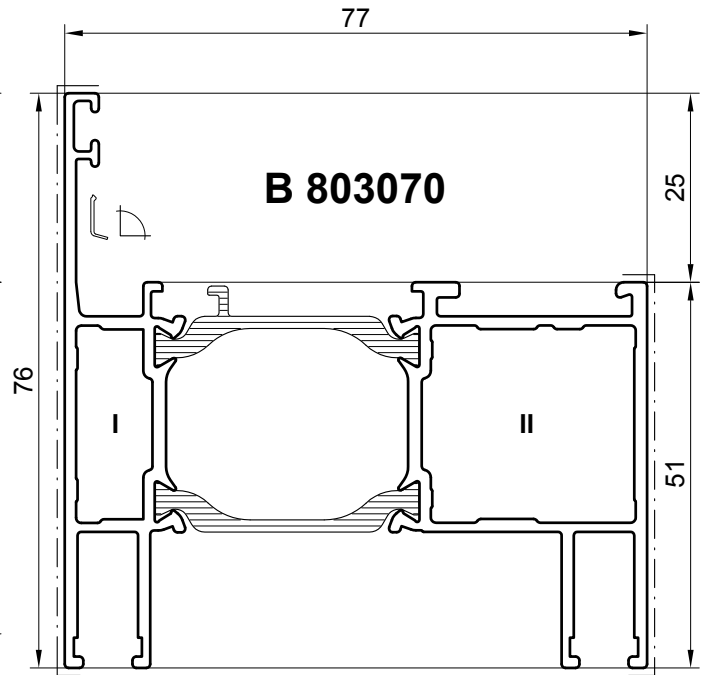
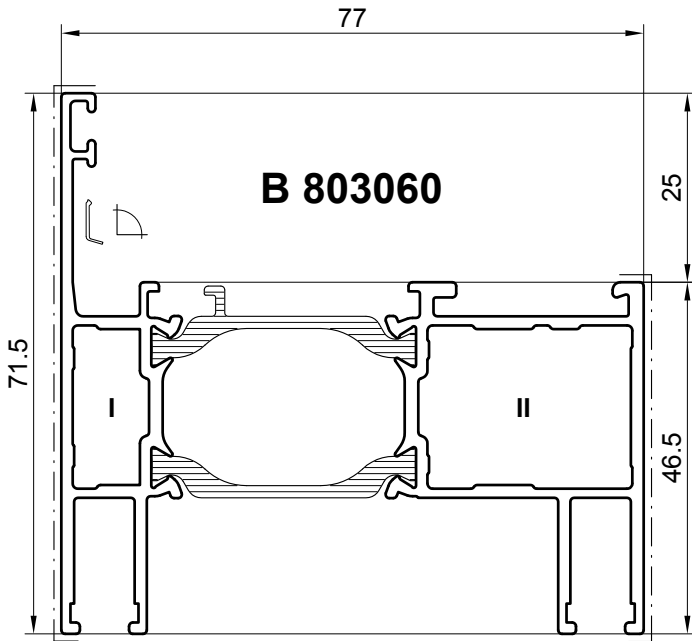

Bei Verwendung des 160kg DK-Beschlages sind bandseitig verstärkte Eckwinkel erforderlich.

Siehe Register Beschläge

If the 160 kg turn-tilt fitting is used, reinforced corner brackets are required on the hinge side.

See register Fittings

Stanzmesser und Stanzwerkzeuge: siehe Register **Werkzeuge**

Punch knives and punching tools: refer to register **Tools**

M 1:1
Scale 1:1

01.7000900

	Außenkammer External profile chamber					Innenkammer Internal profile chamber					
		I				II					
verpressbar verstiftbar nachträglich verklebbar retro gluing after assembly											
B 803060	Z 914240	Z 914295	2 x Z 911049	Z 911187	-	-	Z 911956	Z 912316	2 x Z 900023	Z 911187	Z 914710
B 803070	Z 914240	Z 914296	2 x Z 911049	Z 911187	-	-	Z 911027	Z 911030	2 x Z 900023	Z 911187	Z 914710
B 803060	Z 914234 L Z 914235 R	Z 914374	2 x Z 911513	Z 911187	Z 917301	-	Z 914383	-	2 x Z 914351	Z 911187	Z 914710
B 803070	Z 914234 L Z 914235 R	Z 914375	2 x Z 911513	Z 911187	Z 917302	-	Z 914384	-	2 x Z 914351	Z 911187	Z 914710

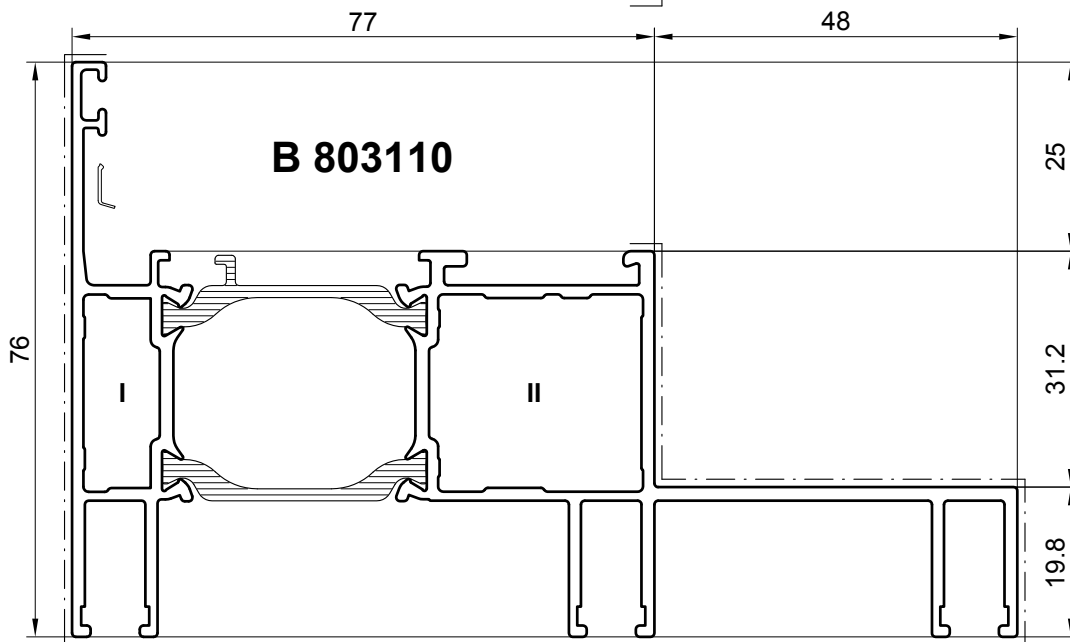
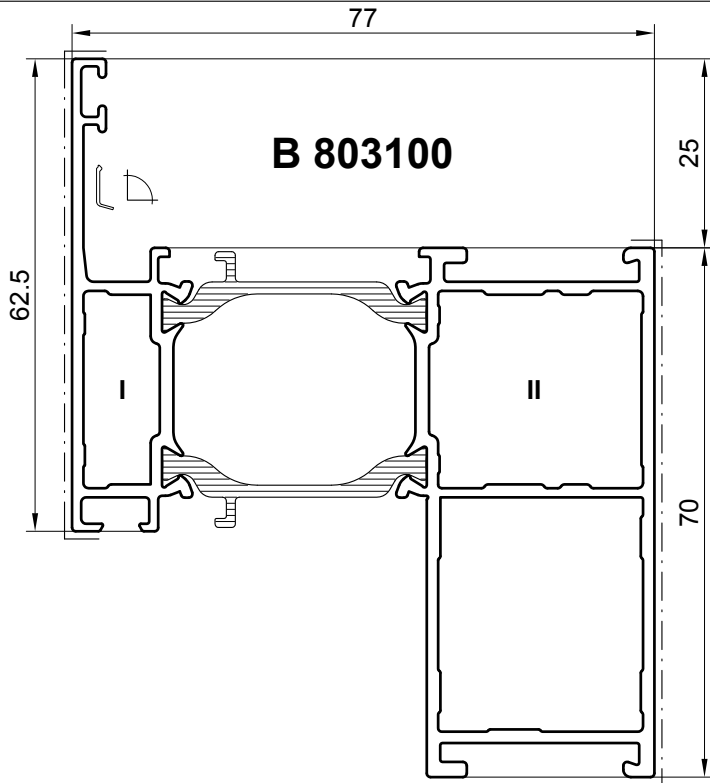

M 1:1
Scale 1:1

Stanzmesser und Stanzwerkzeuge: siehe Register **Werkzeuge**
Punch knives and punching tools: refer to register **Tools**

	Außenkammer External profile chamber					Innenkammer Internal profile chamber					
	I					II					
verpressbar crimpable verstiftbar nailable nachträglich verklebbar retro gluing after assembly											
B 803100	Z 914240	Z 914296	2 x Z 911049	Z 911187	-	-	Z 911027	-	2 x Z 900023	Z 911187	Z 914710
B 803100											
B 803100	Z 914234 L Z 914235 R	Z 914375	2 x Z 911513	Z 911187	Z 917302	-	Z 914384	-	2 x Z 914351	Z 911187	Z 914710
B 803110	Z 914234 L Z 914235 R	Z 914375	2 x Z 911513	Z 911187	Z 917302	-	Z 914384	-	2 x Z 914351	Z 911187	Z 914710

018001000

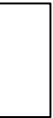

B 803120

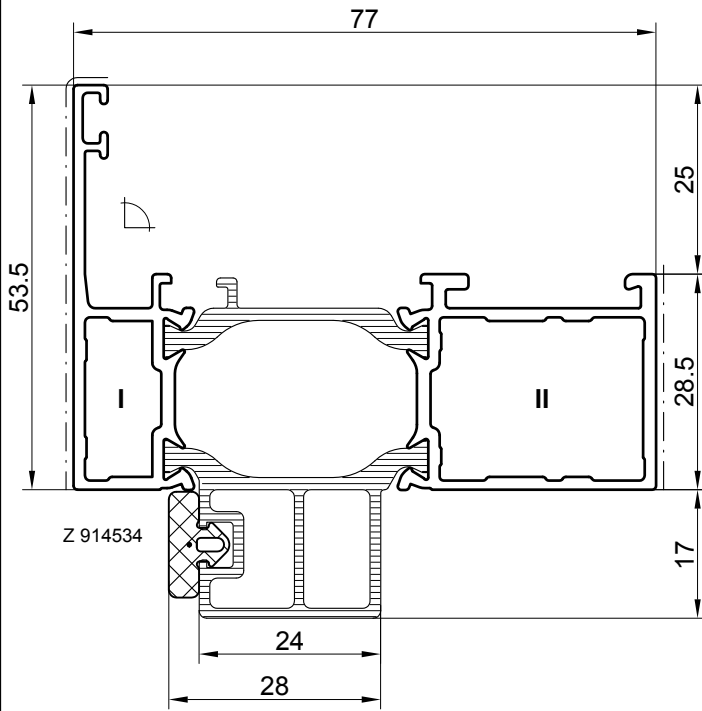

Bitte die Dichtung separat bestellen
Please order the gasket separately

Die Dichtung kann alternativ im Blendrahmenprofil zugesägt werden
An alternative method is to cut the profile and gasket simultaneously

B 803160

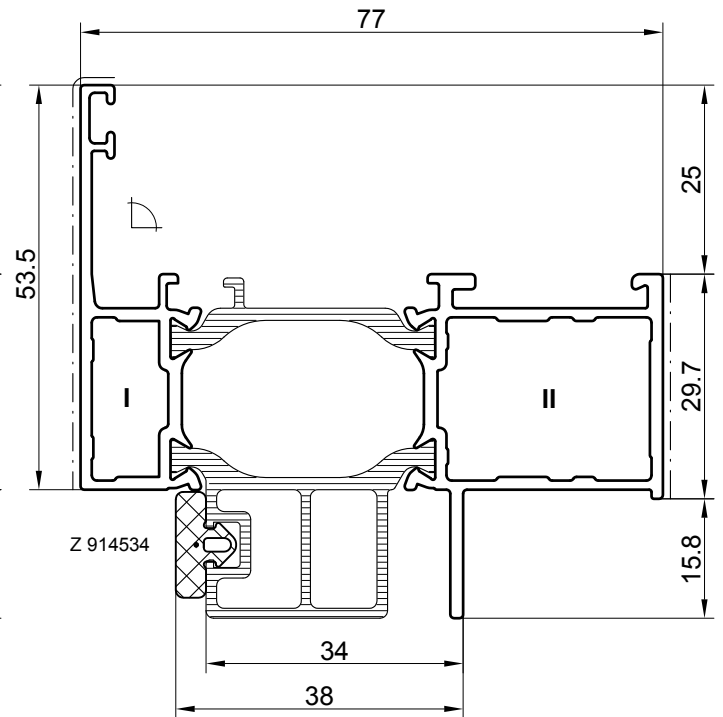











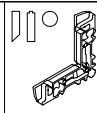

Bitte die Dichtung separat bestellen
Please order the gasket separately

Stanzmesser und Stanzwerkzeuge: siehe Register **Werkzeuge**
Punch knives and punching tools: refer to register **Tools**

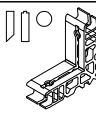
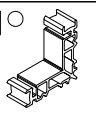
M 1:1
Scale 1:1

018003200

	Außenkammer External profile chamber				Innenkammer Internal profile chamber					
		I				II				
<ul style="list-style-type: none">  verpressbar crimpable  verstiftbar nailable  nachträglich verklebbar retro gluing after assembly 										
B 803120	Z 914240	Z 914295	2 x Z 911049	Z 911187	-	Z 911956	Z 912316	2 x Z 900023	Z 911187	Z 914710
B 803160	Z 914240	Z 914295	2 x Z 911049	Z 911187	-	Z 911956	Z 912316	2 x Z 900023	Z 911187	Z 914710



B 803900

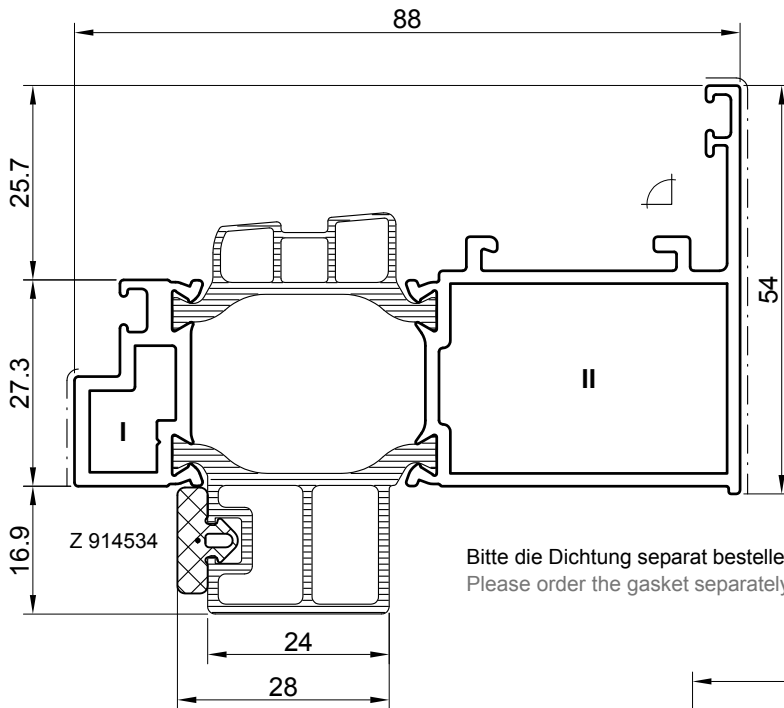

Bitte die Dichtung separat bestellen
Please order the gasket separately

B 803910

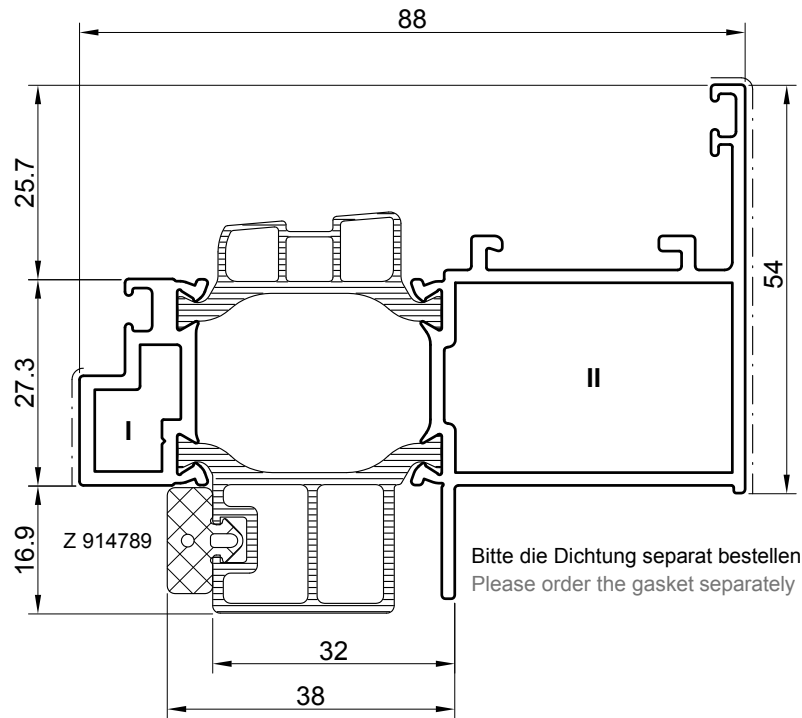

Bitte die Dichtung separat bestellen
Please order the gasket separately

Die Dichtung kann alternativ im Blendrahmenprofil zugesägt werden
An alternative method is to cut the profile and gasket simultaneously

* Bei Einsatz eines Senk-Klapp Beschlages für obere Ecken erforderlich. Bitte Verarbeitungshinweise beachten!
* If using a top-hung projecting out window stay-arm, for upper edges required. Please refer to Processing!

Stanzmesser und Stanzwerkzeuge: siehe Register **Werkzeuge**
Punch knives and punching tools: refer to register **Tools**

M 1:1
Scale 1:1

	Außenkammer External profile chamber					Innenkammer Internal profile chamber						
	I	II	III	IV	V	VI	VII	VIII	IX	X		
verpressbar crimpable												
verstiftbar nailable												
nachträglich verklebbar retro gluing after assembly												
B 803900	-	Z 914571	-	-	-	-	Z 914790	Z 914764 Z 917153 *	2 x Z 900023	Z 911187	Z 914574	
B 803910	-	Z 914571	-	-	-	-	Z 914790	Z 914764 Z 917153 *	2 x Z 900023	Z 911187	Z 914574	

020004300

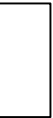

P 803712

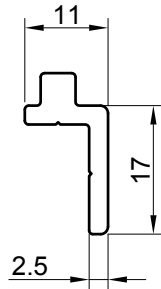

P 803713

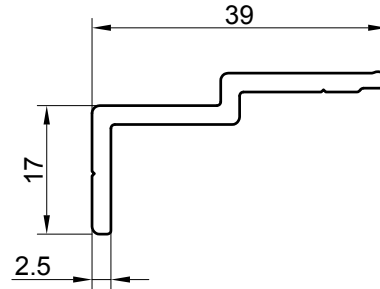

Bitte die Sägeauflage Z 917400 separat bestellen
Please order the spacer for sawing Z 917400 separately

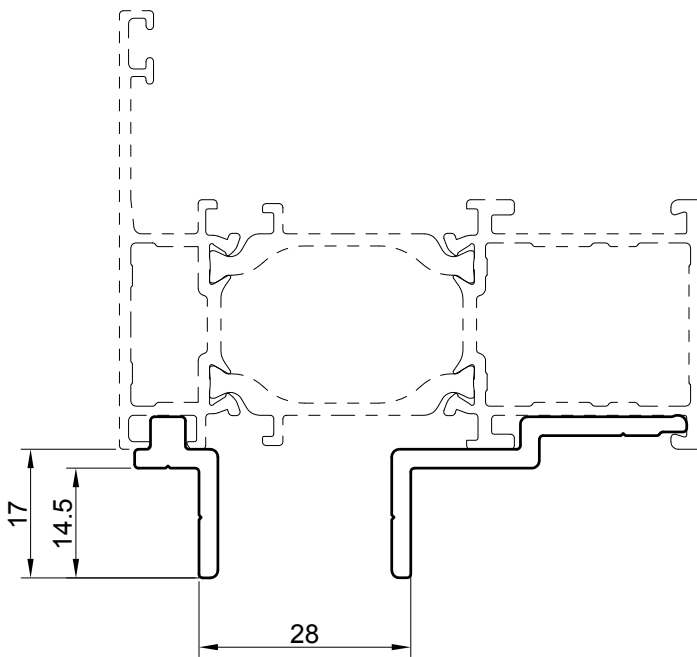
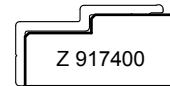

Einspannprofile sind passend für folgende Blendrahmen:
Interlocking profiles fits to the fixed frame profiles:

- B 803000
- B 803010
- B 803020
- B 803030
- B 803040
- B 803050
- B 803140
- B 803150
- B 803170
- B 803180

02/1004700

Stanzmesser und Stanzwerkzeuge: siehe Register **Werkzeuge**
Punch knives and punching tools: refer to register **Tools**

M 1:1
Scale 1:1

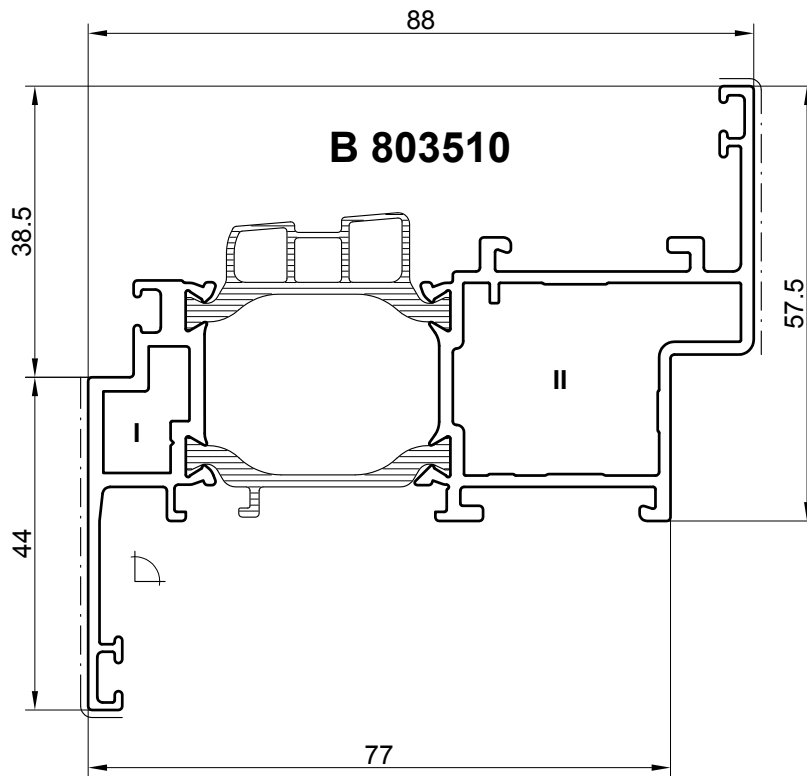
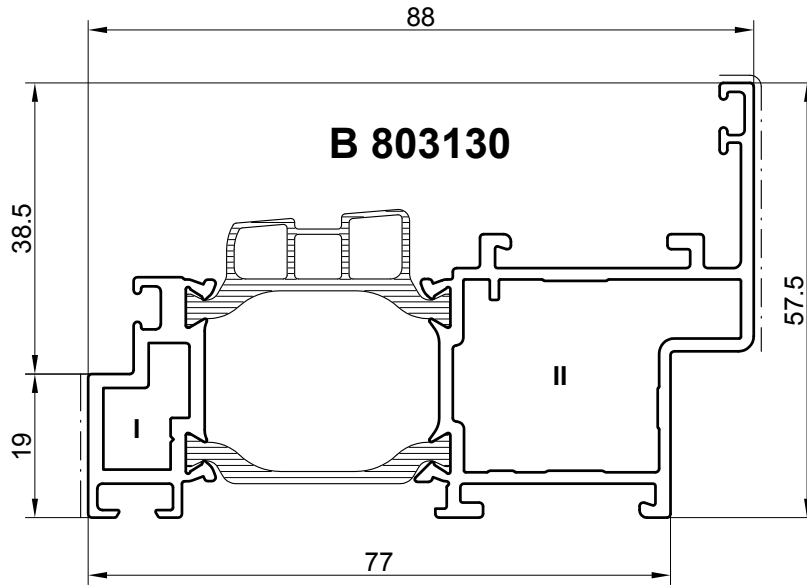

* Bei Einsatz eines Senk-Klapp Beschlages für obere Ecken erforderlich. Bitte Verarbeitungshinweise beachten!
 * If using a top-hung projecting out window stay-arm, for upper edges required. Please refer to Processing!

Stanzmesser und Stanzwerkzeuge: siehe Register **Werkzeuge**
 Punch knives and punching tools: refer to register **Tools**

M 1:1
 Scale 1:1

	Außenkammer External profile chamber					Innenkammer Internal profile chamber					
		I					II				
◻ verpressbar crimpable ◻ verstiftbar nailable ○ nachträglich verklebbar retro gluing after assembly	◻					◻					
B 803130	-	Z 914571	-	-	-	Z 914569	Z 914713 Z 914570 *	2 x Z 900023	Z 911187	Z 914710	
B 803510	Z 914240	Z 914571	-	-	-	Z 914569	Z 914713 Z 914570 *	2 x Z 900023	Z 911187	Z 914710	

022003301

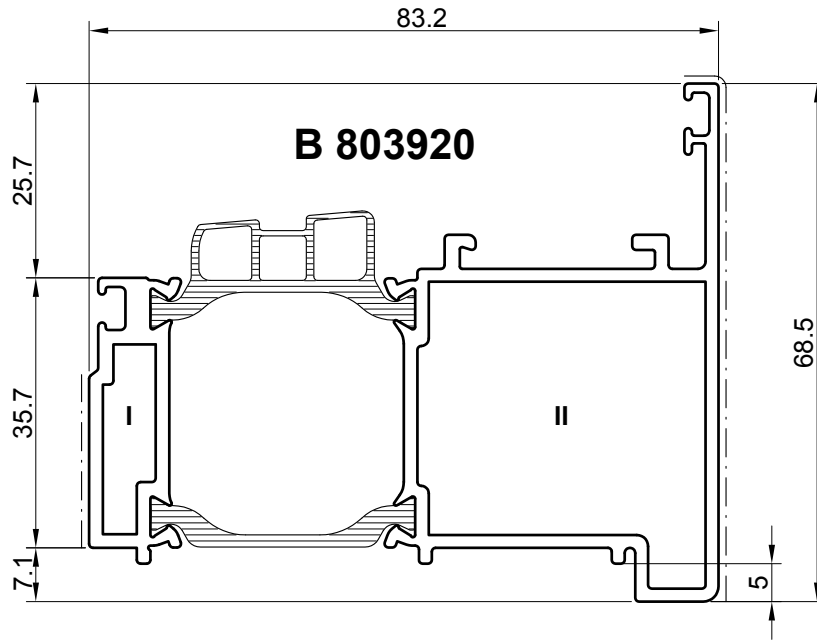
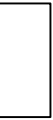

* Bei Einsatz eines Senk-Klapp Beschlages für obere Ecken erforderlich. Bitte Verarbeitungshinweise beachten!
 * If using a top-hung projecting out window stay-arm, for upper edges required. Please refer to Processing!

Stanzmesser und Stanzwerkzeuge: siehe Register **Werkzeuge**
 Punch knives and punching tools: refer to register **Tools**

M 1:1
 Scale 1:1

02.3004400

	Außenkammer External profile chamber					Innenkammer Internal profile chamber					
	I	II				I				II	
verpressbar crimpable verstiftbar nailable nachträglich verklebbar retro gluing after assembly											
B 803920	-	Z 914954	-	-	-	Z 914952	Z 914953 Z 917154 *	2 x Z 900023	Z 911187	Z 914574	

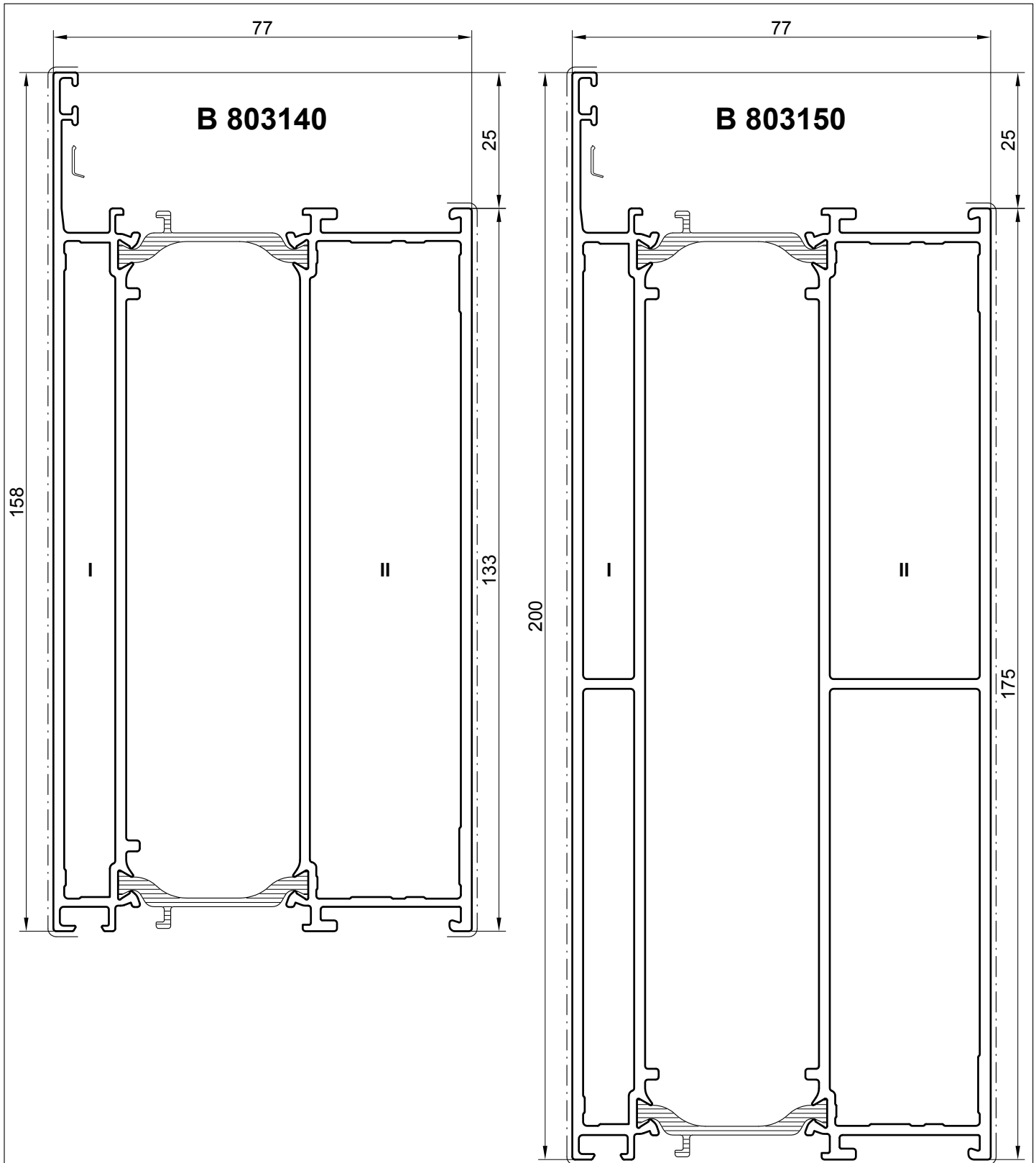

Stanzmesser und Stanzwerkzeuge: siehe Register **Werkzeuge**
Punch knives and punching tools: refer to register **Tools**

M 1:1
Scale 1:1

	Außenkammer External profile chamber					Innenkammer Internal profile chamber					
	I					II					
B 803140	Z 914234 L Z 914235 R	Z 914719	2 x Z 911513	Z 911187	2 x Z 914289	-	Z 914720		2 x Z 914351	Z 911187	Z 914710
B 803150	Z 914234 L Z 914235 R	Z 914721	2 x Z 911513	Z 911187	2 x Z 914289	-	Z 914722		2 x Z 914351	Z 911187	Z 914710

02403900

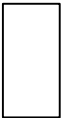

B 803170

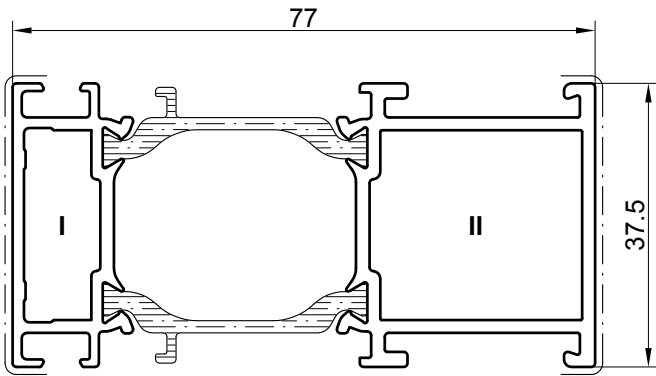

B 803180

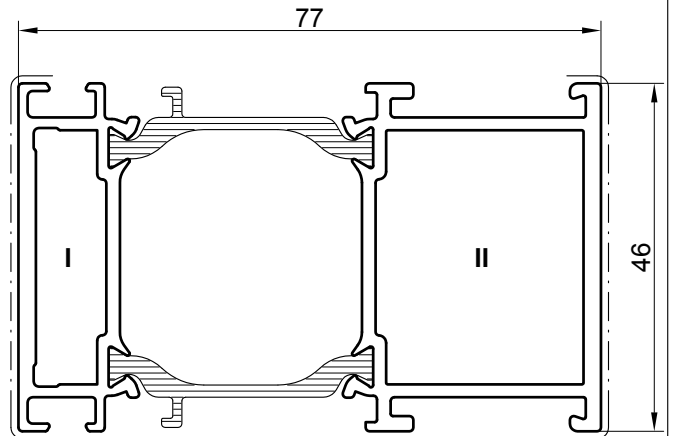

P 803711

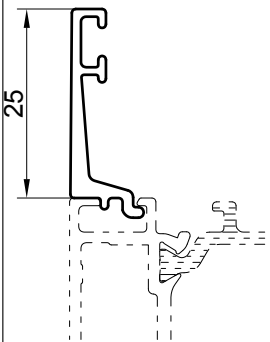

Stoßverbinder für B 803170 / B 803180: T-brackets for B 803170 / B 803180:

B 803170 / B 803180 verbunden mit Profil: B 803170 / B 803180 connected with profile:									
B 803000 B 803300	B 803010 B 803310	B 803020 B 803320	B 803030 B 803330 B 803180	B 803040 B 803340	B 803050 B 803350	B 803360	B 803370	B 803380	B 803140
Stoßverbinder Außenkammer					T-bracket external profile chamber				
Z 917788	Z 917789	Z 917790	Z 917791	Z 917792	Z 917793	Z 917794	Z 917795	Z 917796	Z 917797
Stoßverbinder Innenkammer					T-bracket internal profile chamber				
Z 914382	Z 914383	Z 914384	Z 914385	Z 914386	Z 914387	Z 914388	Z 914389	Z 914390	Z 914720

Stanzmesser und Stanzwerkzeuge: siehe Register **Werkzeuge**
Punch knives and punching tools: refer to register **Tools**

M 1:1
Scale 1:1

	Außenkammer External profile chamber					Innenkammer Internal profile chamber					
		I				II					
<ul style="list-style-type: none"> verpressbar crimpable verstiftbar nailable nachträglich verklebbar retro gluing after assembly 											
B 803170	-	Z 914296	2 x Z 911049	Z 911187	-	-	Z 911027	Z 911030	2 x Z 900023	Z 911187	Z 914710
B 803180	-	Z 914297	2 x Z 911049	Z 911187	-	-	Z 911120	Z 911121	2 x Z 900023	Z 911187	Z 914710
B 803170	-	Z 914375	2 x Z 911513	Z 911187	Z 917302	-	Z 914384	-	2 x Z 914351	Z 911187	Z 914710
B 803180	-	Z 914376	2 x Z 911513	Z 911187	Z 917303	-	Z 914385	-	2 x Z 914351	Z 911187	Z 914710

025004000

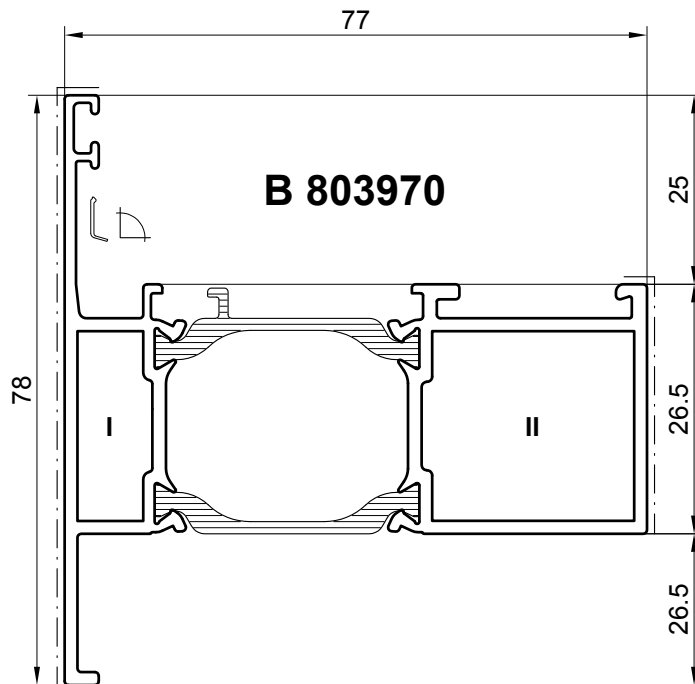
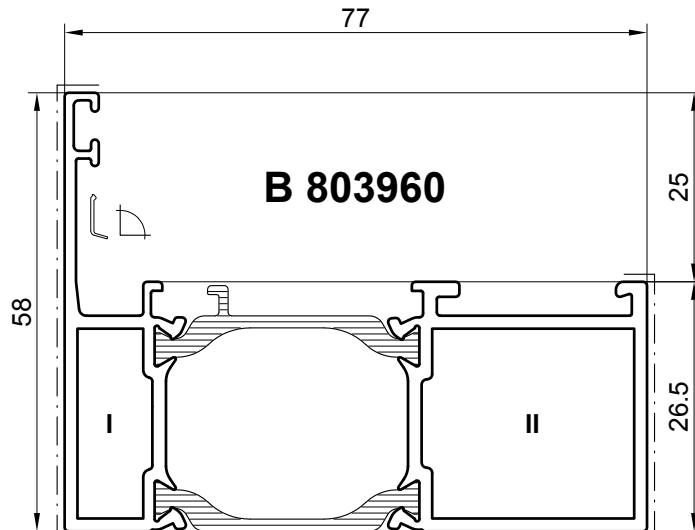

Stanzmesser und Stanzwerkzeuge: siehe Register **Werkzeuge**
Punch knives and punching tools: refer to register **Tools**

M 1:1
Scale 1:1

	Außenkammer External profile chamber					Innenkammer Internal profile chamber					
	I					II					
<ul style="list-style-type: none"> verpressbar crimpable verstitfbar nailable nachträglich verklebbar retro gluing after assembly 											
B 803960	Z 914240	Z 914296	2 x Z 911049	Z 911187		-	Z 911027	Z 911030	2 x Z 900023	Z 911187	Z 914710
B 803970	Z 914240	Z 914296	2 x Z 911049	Z 911187		-	Z 911027	Z 911030	2 x Z 900023	Z 911187	Z 914710
								-			
B 803960	Z 914234 L Z 914235 R	Z 914375	2 x Z 911513	Z 911187	Z 917302	-	Z 914384	-	2 x Z 914351	Z 911187	Z 914710
B 803970	Z 914234 L Z 914235 R	Z 914375	2 x Z 911513	Z 911187	Z 917302	-	Z 914384	-	2 x Z 914351	Z 911187	Z 914710

026004500