

B 803400

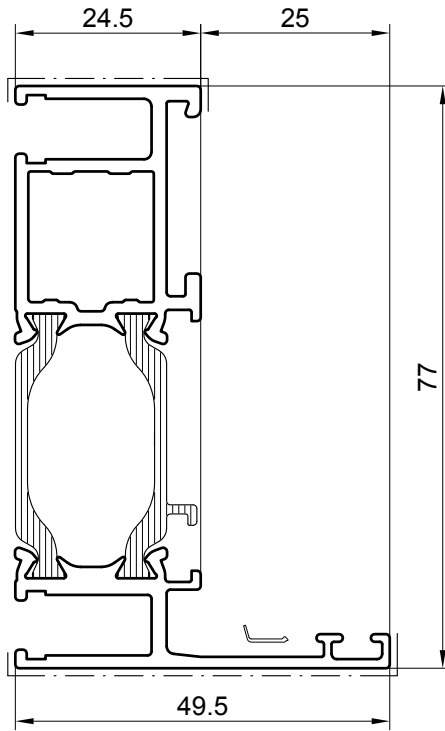

B 803410

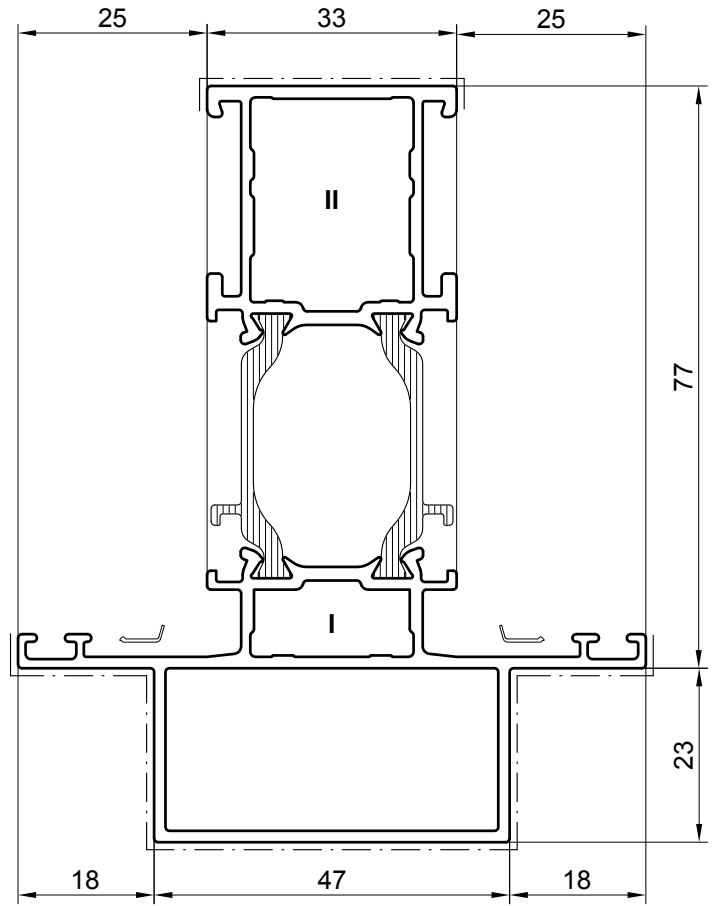

B 803520

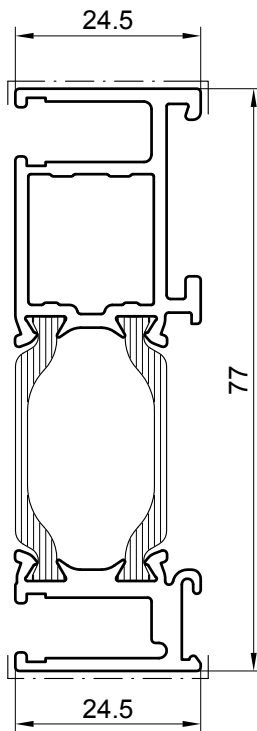

Stoßverbinder für **B 803520**:
T-brackets for **B 803520**:

B 803520 verbunden mit Profil: B 803520 connected with profile:									
B 803040 B 803340	B 803380	B 803100	B 803010 B 803060 B 803080 B 803310 B 803410	B 803020 B 803070 B 803090 B 803320 B 803500 B 803170 B 803960 B 803970	B 803300 B 803000	B 803030 B 803330 B 803180	B 803050 B 803350	B 803360	B 803370
Z 917079	Z 917080	Z 917159	Z 917200	Z 917201	Z 917390	Z 917391	Z 917392	Z 917393	Z 917394
Stoßverbinder Außenkammer T-bracket external profile chamber									
Stoßverbinder Innenkammer, siehe entsprechendes Profil T-bracket internal profile chamber, refer to the accordiant Profile									

Stanzmesser und Stanzwerkzeuge: siehe Register **Werkzeuge**
Punch knives and punching tools: refer to register **Tools**

M 1:1
Scale 1:1

033001700

	Außenkammer External profile chamber					Innenkammer Internal profile chamber					
	I					II					
B 803400	Z 914234 L Z 914235 R	-	-	-	-	-	-	-	-	-	-
B 803410	Z 914234 L Z 914235 R	Z 914374	2 x Z 911513	Z 911187	Z 917301	-	Z 914383	-	2 x Z 914351	Z 911187	Z 914710

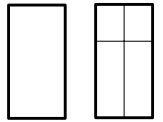

B 803400

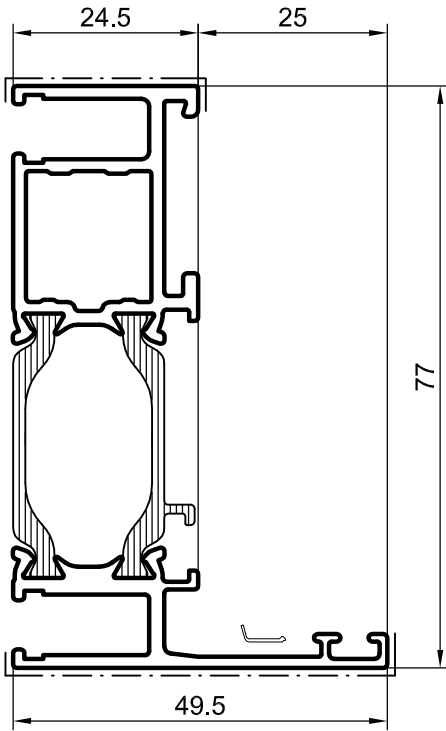

B 803410

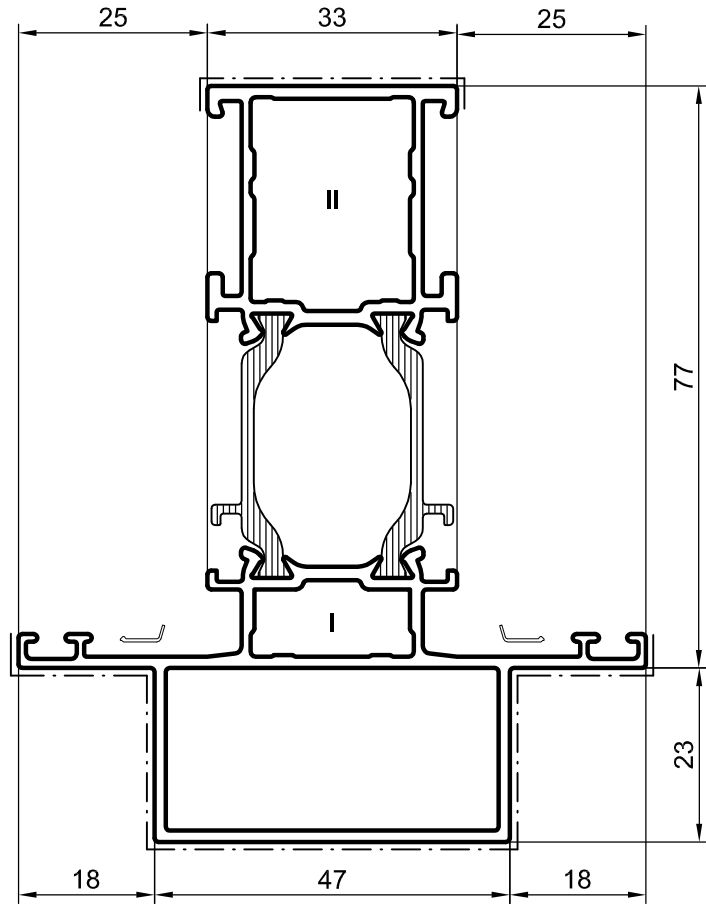

B 803522

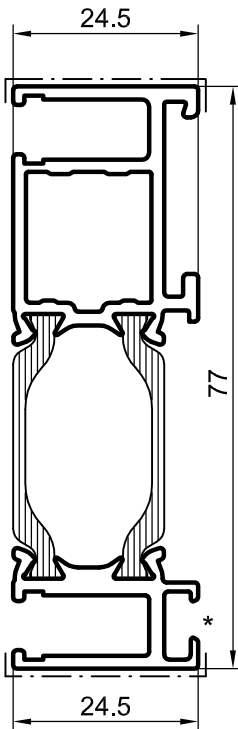

Stoßverbinder für * **Nuten, alle Profile**
T-brackets for * **notches, all profiles**

Profile Profiles									
B 803000	B 803010	B 803020	B 803030	B 803040	B 803050	B 803360	B 803370	B 803380	B 803140
B 803300	B 803310	B 803170	B 803330	B 803340	B 803350				
B 803082	B 803083	B 803320	B 803180						
B 803502		B 803093	B 803503						
Stoßverbinder Außenkammer					T-bracket external profile chamber				
Z 917788	Z 917789	Z 917790	Z 917791	Z 917792	Z 917793	Z 917794	Z 917795	Z 917796	Z 917797
Stoßverbinder Innenkammer					T-bracket internal profile chamber				
Z 914382	Z 914383	Z 914384	Z 914385	Z 914386	Z 914387	Z 914388	Z 914389	Z 914390	Z 914720

Stanzmesser und Stanzwerkzeuge: siehe Register **Werkzeuge**
Punch knives and punching tools: refer to register **Tools**

M 1:1
Scale 1:1

	Außenkammer External profile chamber					Innenkammer Internal profile chamber					
	I					II					
B 803400	Z 914234 L Z 914235 R	-	-	-	-	-	-	-	-	-	-
B 803410	Z 914234 L Z 914235 R	Z 914374	2 x Z 911513	Z 911187	Z 917301	-	Z 914383	-	2 x Z 914351	Z 911187	Z 914710

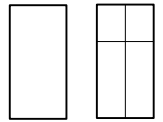

B 803420

B 803430

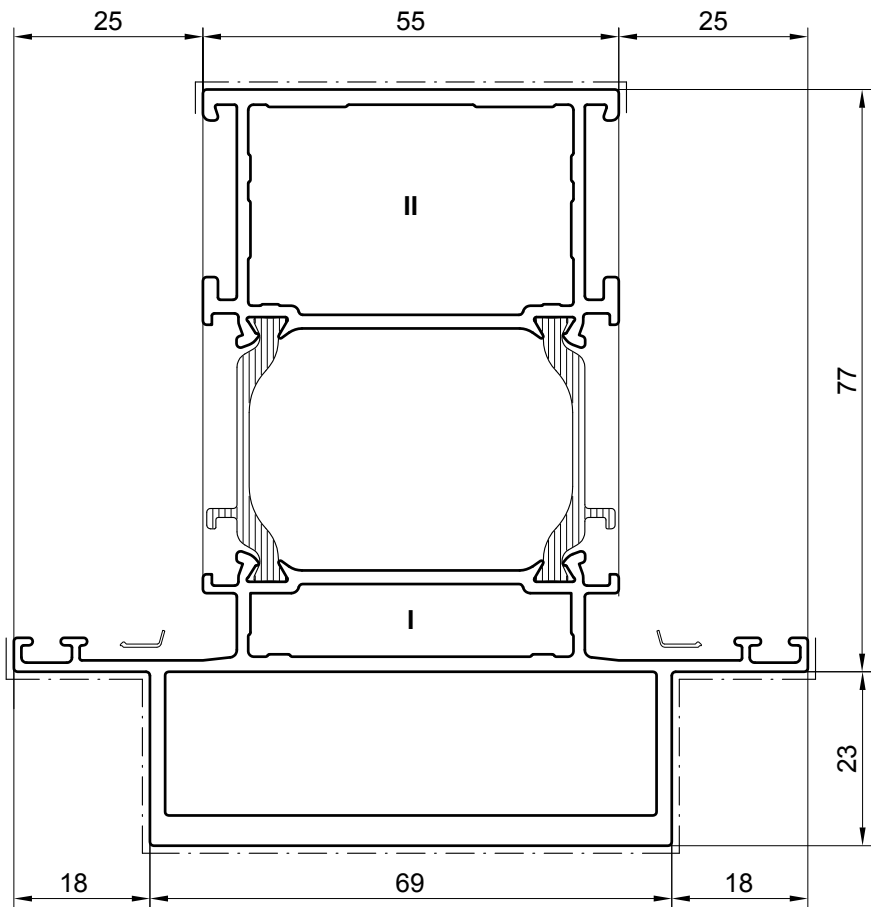
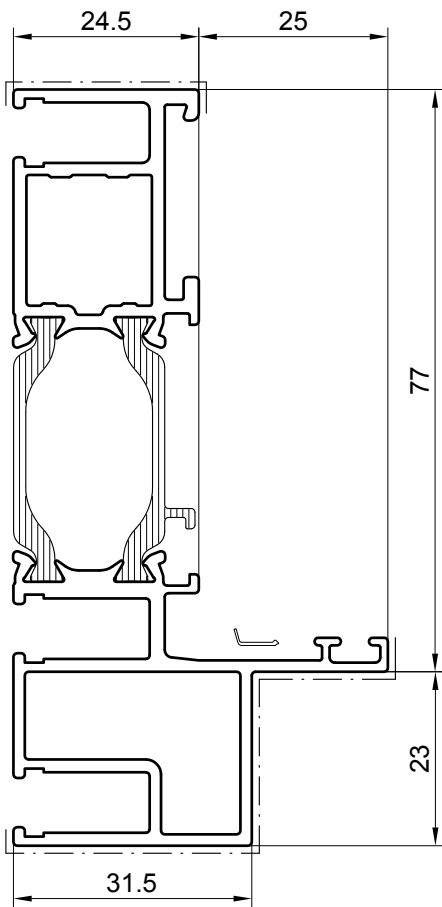

Stanzmesser und Stanzwerkzeuge: siehe Register **Werkzeuge**
Punch knives and punching tools: refer to register **Tools**

M 1:1
Scale 1:1

	Außenkammer External profile chamber					Innenkammer Internal profile chamber					
	I					II					
B 803420	Z 914234 L Z 914235 R	-	-	-	-	-	-	-	-	-	-
B 803430	Z 914234 L Z 914235 R	Z 914377	2 x Z 911513	Z 911187	2 x Z 914289	-	Z 914386	-	2 x Z 914351	Z 911187	Z 914710

03401800

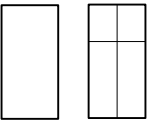

B 803440

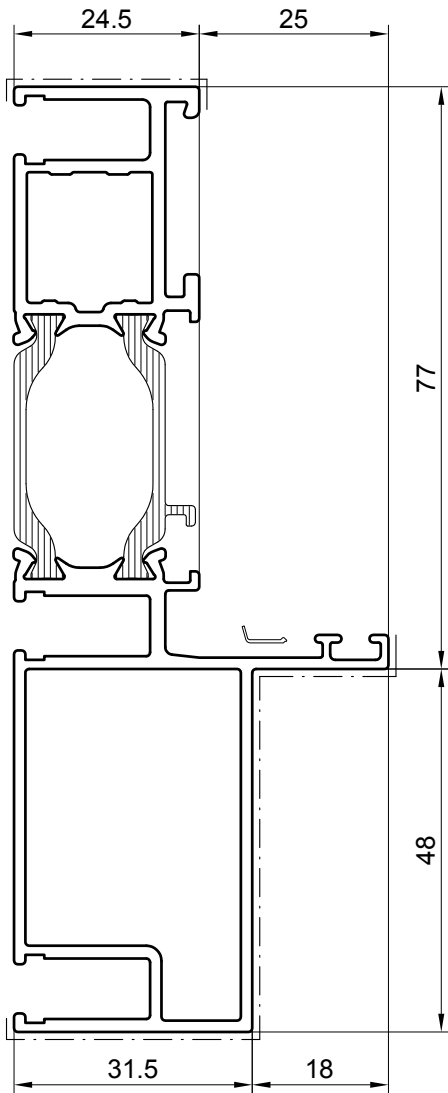

B 803450

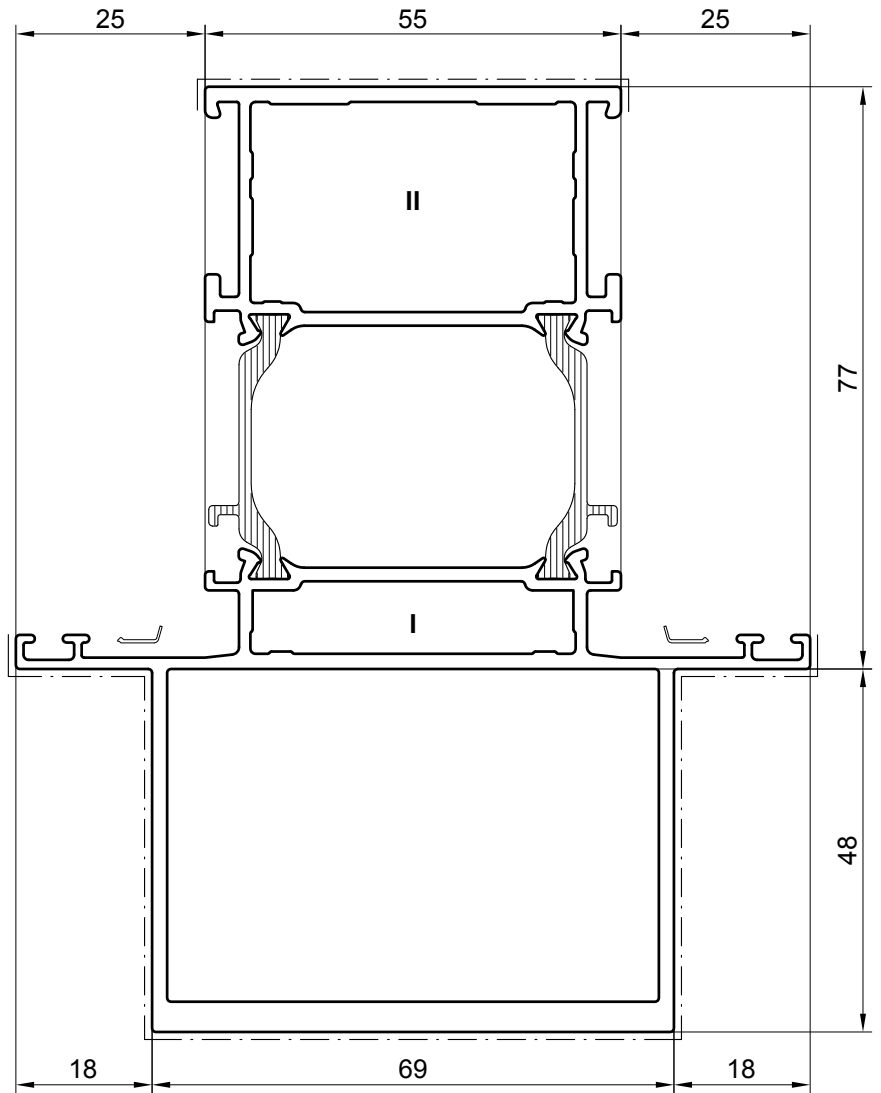

Stanzmesser und Stanzwerkzeuge: siehe Register **Werkzeuge**
Punch knives and punching tools: refer to register **Tools**

M 1:1
Scale 1:1

03.5001900

	Außenkammer External profile chamber					Innenkammer Internal profile chamber					
	I					II					
B 803440	Z 914234 L Z 914235 R	Z 914377	-	-	-	-	-	-	-	-	-
B 803450	Z 914234 L Z 914235 R	Z 914377	2 x Z 911513	Z 911187	2 x Z 914289	-	Z 914386	-	2 x Z 914351	Z 911187	Z 914710

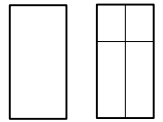

B 803460

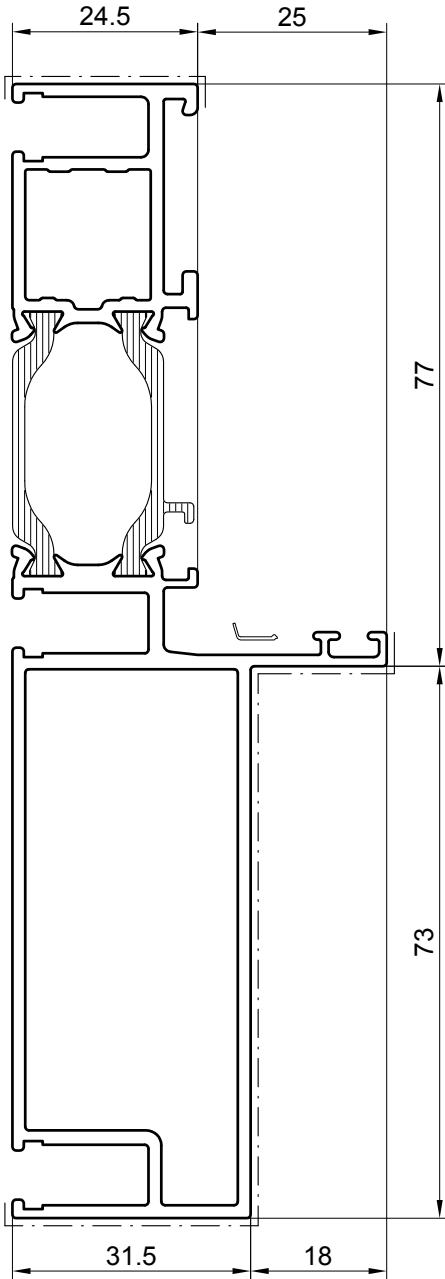

B 803470

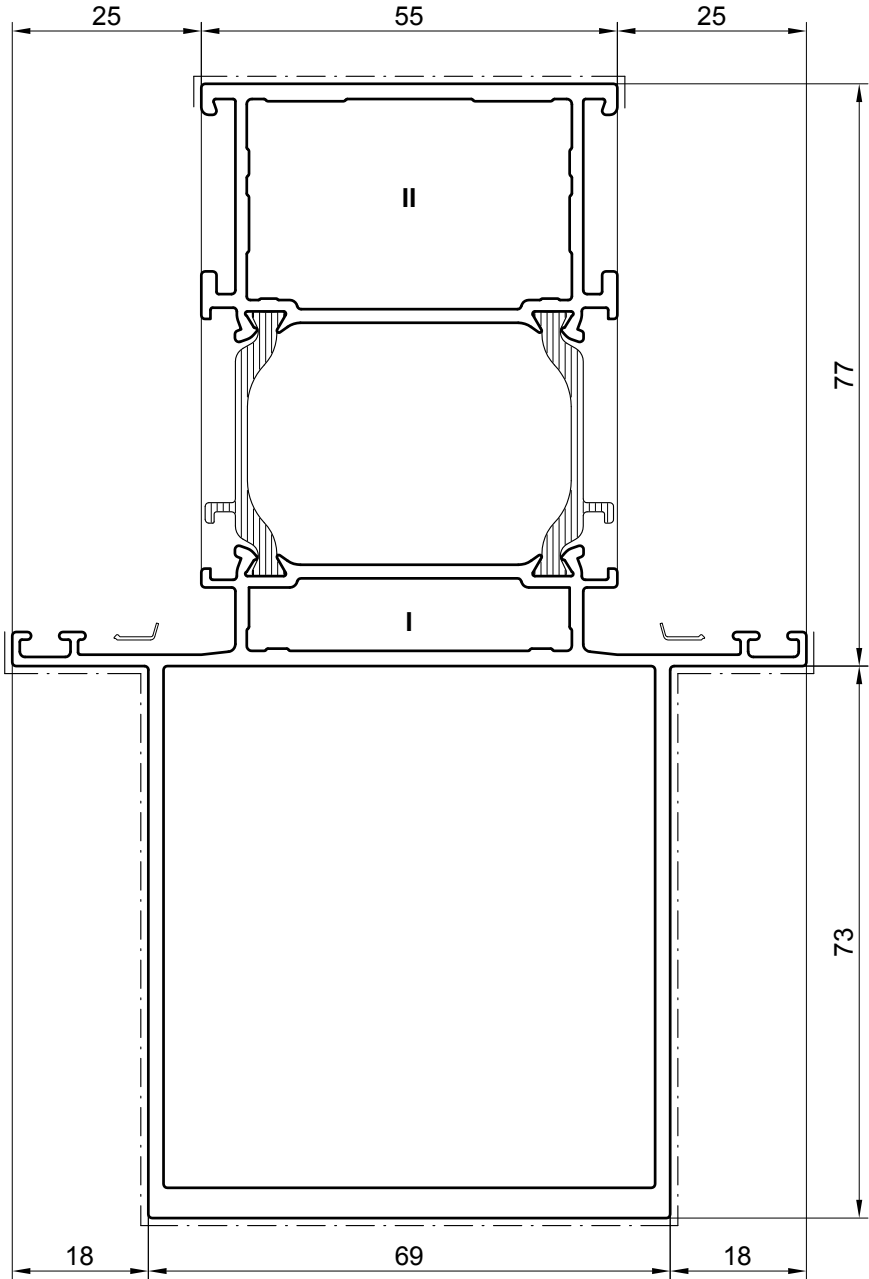

Stanzmesser und Stanzwerkzeuge: siehe Register **Werkzeuge**
Punch knives and punching tools: refer to register **Tools**

M 1:1
Scale 1:1

	Außenkammer External profile chamber						Innenkammer Internal profile chamber				
	I						II				
B 803460	Z 914234 L Z 914235 R	-	-	-	-	-	-	-	-	-	-
B 803470	Z 914234 L Z 914235 R	Z 914377	2 x Z 911513	Z 911187	2 x Z 914289	-	Z 914386	-	2 x Z 914351	Z 911187	Z 914710

03602000

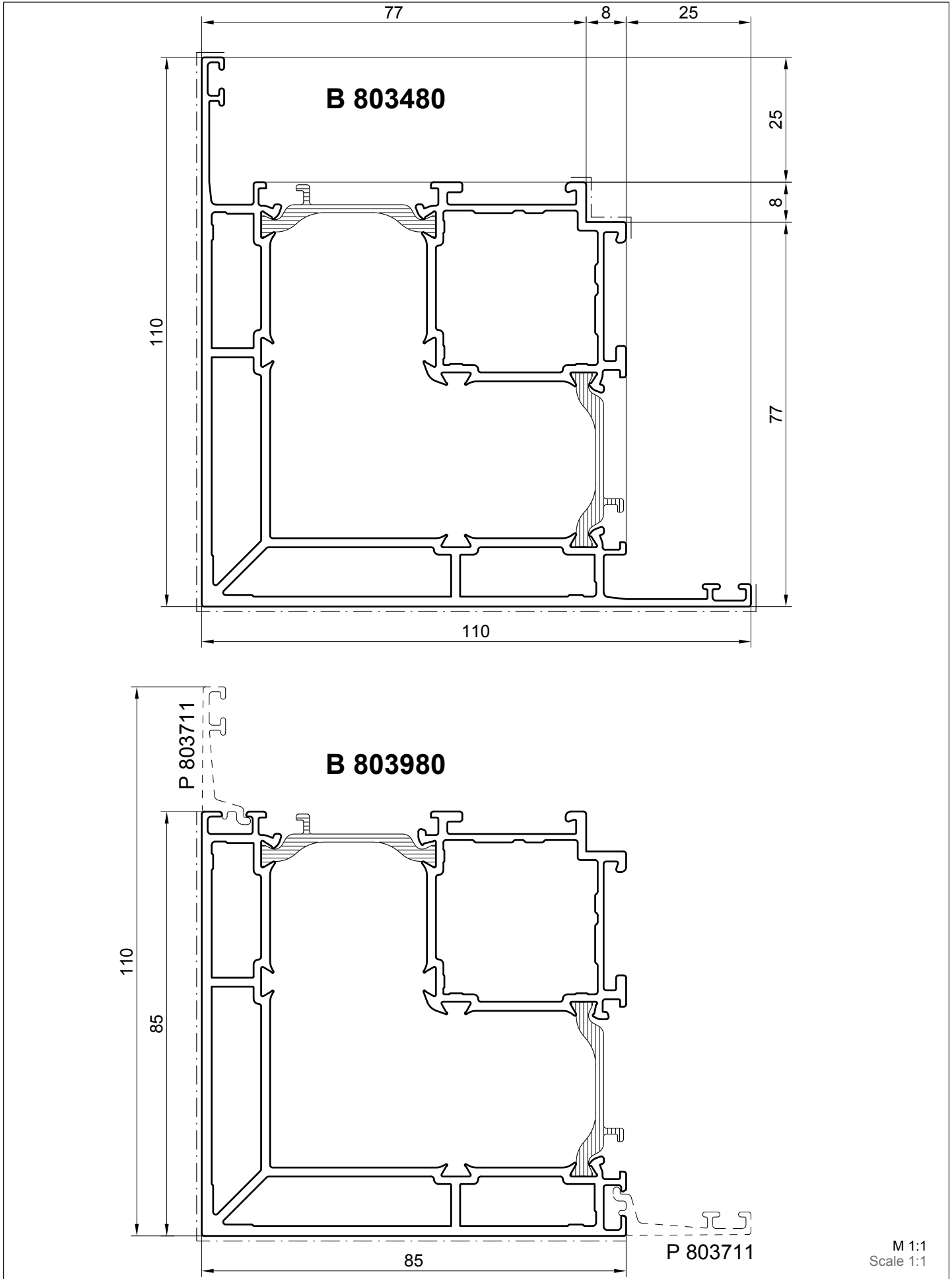
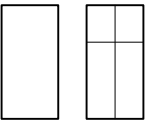

03.7002.100

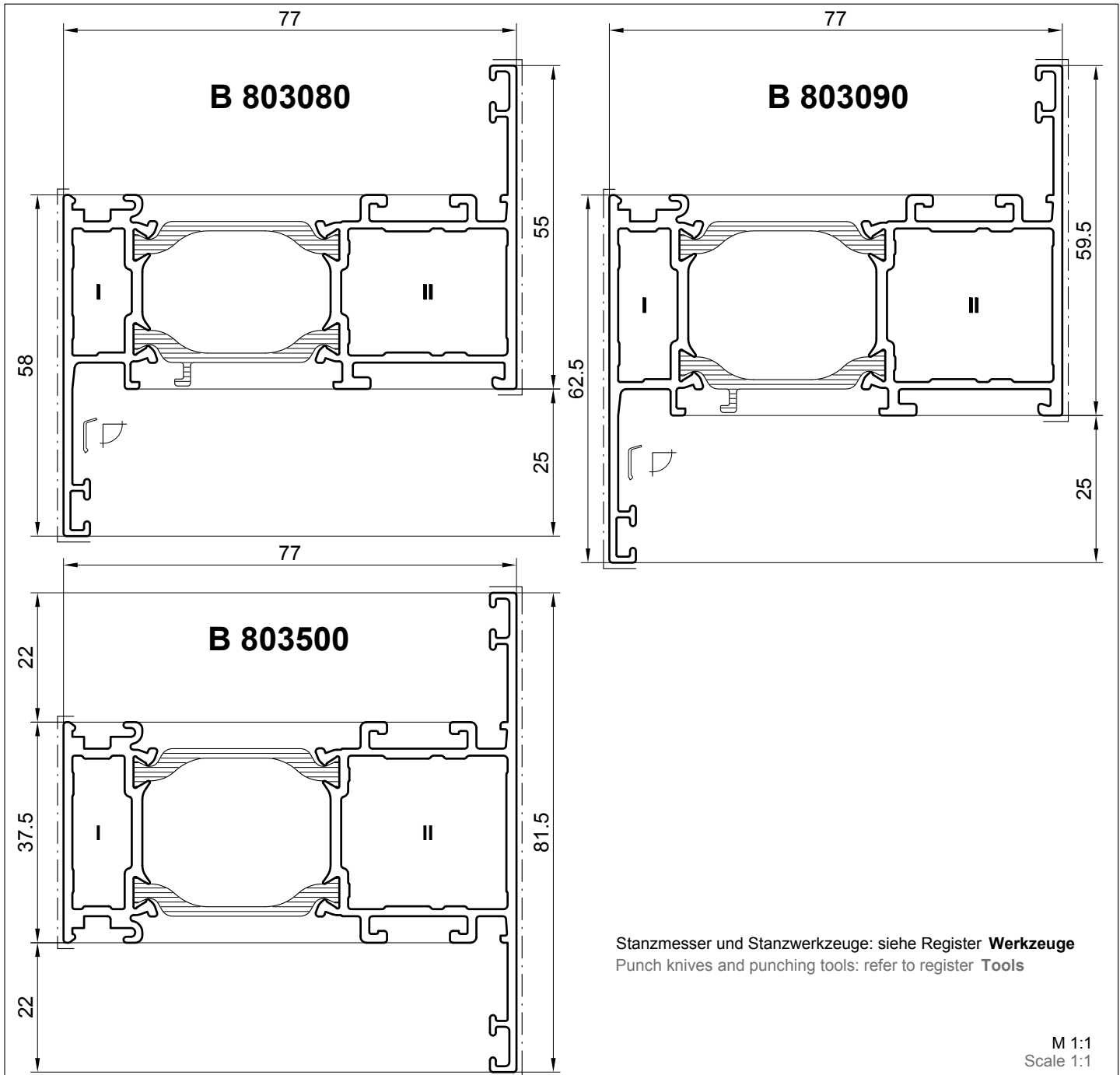
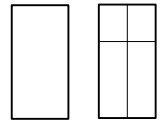

	Außenkammer External profile chamber					Innenkammer Internal profile chamber					
	I	II				II					
verpressbar crimpable verstiftbar nailable nachträglich verklebbar retro gluing after assembly					-						
B 803080	Z 914240	Z 914295	2 x Z 911049	Z 911187	-	-	Z 911956	Z 912316	2 x Z 900023	Z 911187	Z 914434
B 803090	Z 914240	Z 914296	2 x Z 911049	Z 911187	-	-	Z 911027	Z 911030	2 x Z 900023	Z 911187	Z 914434
B 803500	-	-	-	-	-	-	-	-	-	-	-
B 803080	Z 914234 L Z 914235 R	Z 914374	2 x Z 911513	Z 911187	Z 917301	-	Z 914383	-	2 x Z 914351	Z 911187	Z 914434
B 803090	Z 914234 L Z 914235 R	Z 914375	2 x Z 911513	Z 911187	Z 917302	-	Z 914384	-	2 x Z 914351	Z 911187	Z 914434
B 803500	-	Z 914375	2 x Z 911513	Z 911187	Z 917302	-	Z 914384	-	2 x Z 914351	Z 911187	Z 914434

038002200

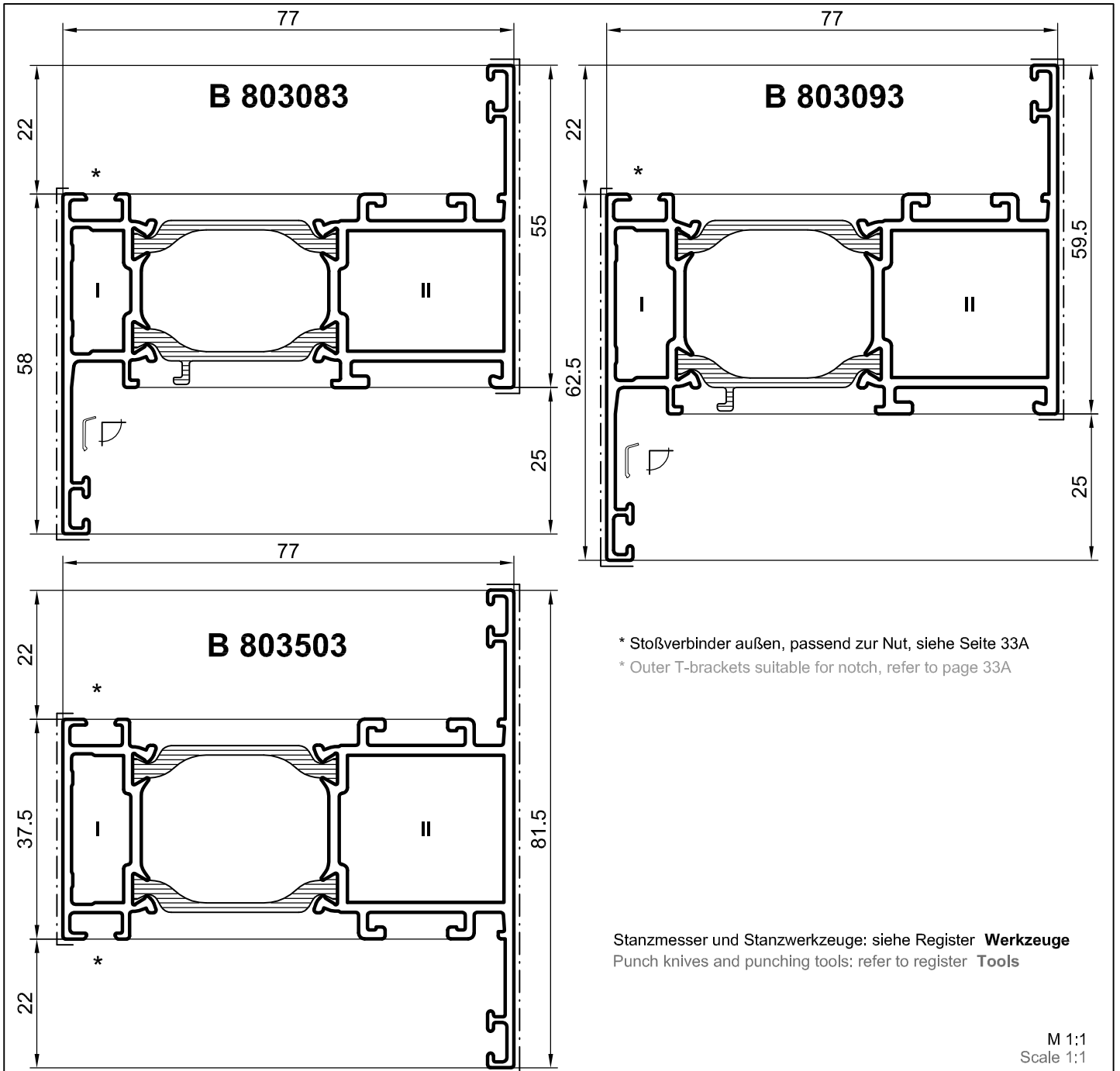
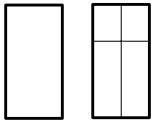

* Stoßverbinder außen, passend zur Nut, siehe Seite 33A

* Outer T-brackets suitable for notch, refer to page 33A

Stanzmesser und Stanzwerkzeuge: siehe Register **Werkzeuge**
Punch knives and punching tools: refer to register **Tools**

M 1:1
Scale 1:1

	Außenkammer External profile chamber					Innenkammer Internal profile chamber					
	I	II				I	II				
B 803083	Z 914240	Z 914295	2 x Z 911049	Z 911187	-	-	Z 911956	Z 912316	2 x Z 900023	Z 911187	Z 914434
B 803093	Z 914240	Z 914296	2 x Z 911049	Z 911187	-	-	Z 911027	Z 911030	2 x Z 900023	Z 911187	Z 914434
B 803503	-	-	-	-	-	-	-	-	-	-	-
B 803083	Z 914234 L Z 914235 R	Z 914374	2 x Z 911513	Z 911187	Z 917301	-	Z 914383	-	2 x Z 914351	Z 911187	Z 914434
B 803093	Z 914234 L Z 914235 R	Z 914375	2 x Z 911513	Z 911187	Z 917302	-	Z 914384	-	2 x Z 914351	Z 911187	Z 914434
B 803503	-	Z 914375	2 x Z 911513	Z 911187	Z 917302	-	Z 914384	-	2 x Z 914351	Z 911187	Z 914434

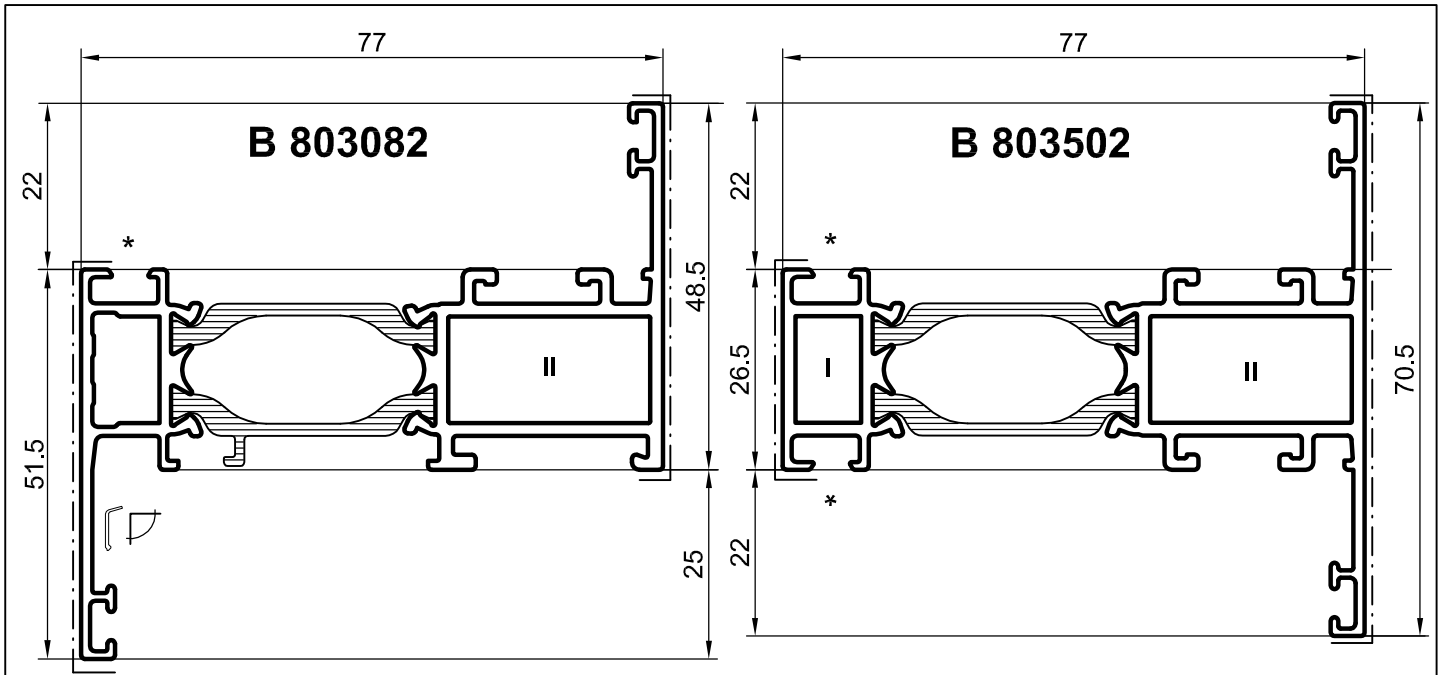
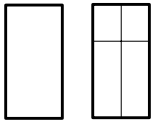

* Stoßverbinder außen, passend zur Nut, siehe Seite 33 A
 * Outer T-brackets suitable for notch, refer to page 33 A

Stanzmesser und Stanzwerkzeuge: siehe Register **Werkzeuge**
 Punch knives and punching tools: refer to register **Tools**

M 1:1
 Scale 1:1

verpressbar crimpable verstiftbar nailable nachträglich verklebbar retro gluing after assembly	Außenkammer External profile chamber					Innenkammer Internal profile chamber					
B 803082	Z 914240	Z 914294			-	-	Z 911486	Z 911488			Z 914710
B 803082											
B 803082	Z 914234 L Z 914235 R	Z 914373	2 x Z 911513	Z 911187	Z 917300	-	Z 914382	-	2 x Z 914351	Z 911187	Z 914710
B 803502		Z 914373	2 x Z 911513	Z 911187	Z 917300	-	Z 914382	-	2 x Z 914351	Z 911187	Z 914710

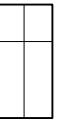

Nur für Festfelder verwendbar
Suitable only for fixed fields

P 803550

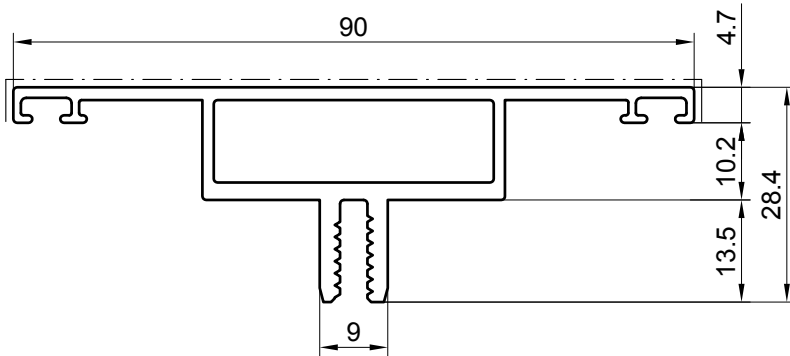

P 803580

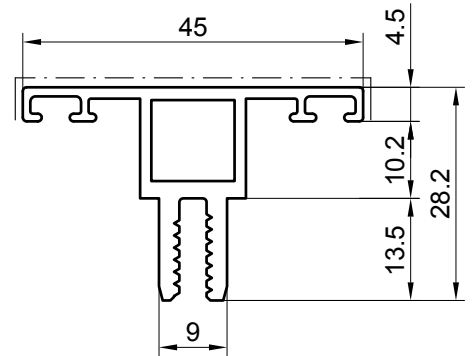

P 803560

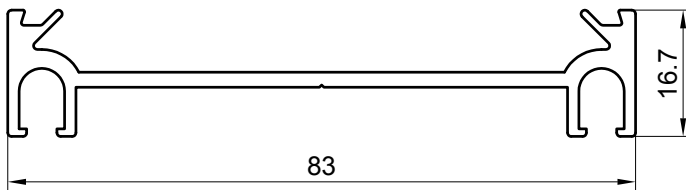

P 803590

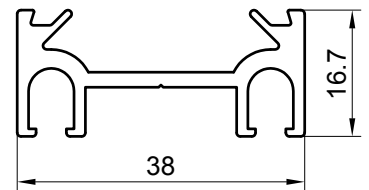

P 803570

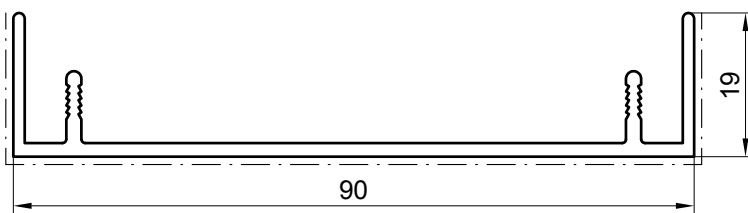

P 803390

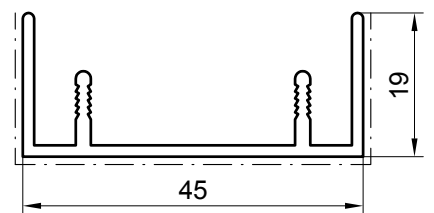

M 1:1
Scale 1:1

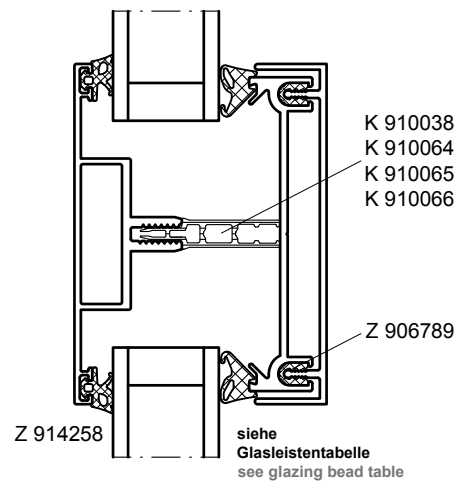

039004600