



Lambda 77 XL, 77 L, 65 M

 Z 994595
Z 994590
Z 994589 Z 994599

 Ø 5 / Ø 7.6
Z 914434
Z 914420

 Z 911737
Z 912717 / Z 912718

 Z 994183

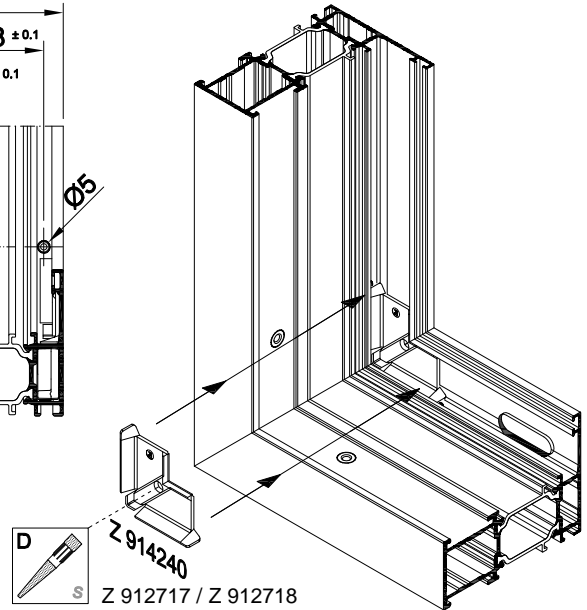
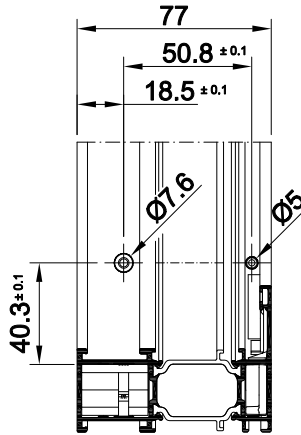
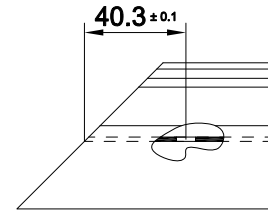
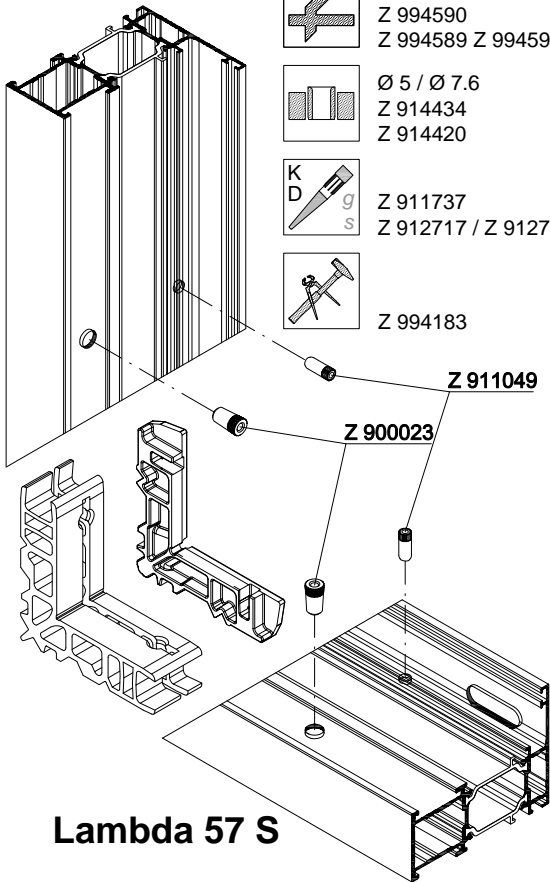

 Z 914240
Z 912717 / Z 912718

Lambda 57 S

 Z 994599

 Ø 7.6
Z 914452

 Z 911737
Z 912717
Z 912718

 Z 907385
Z 994183

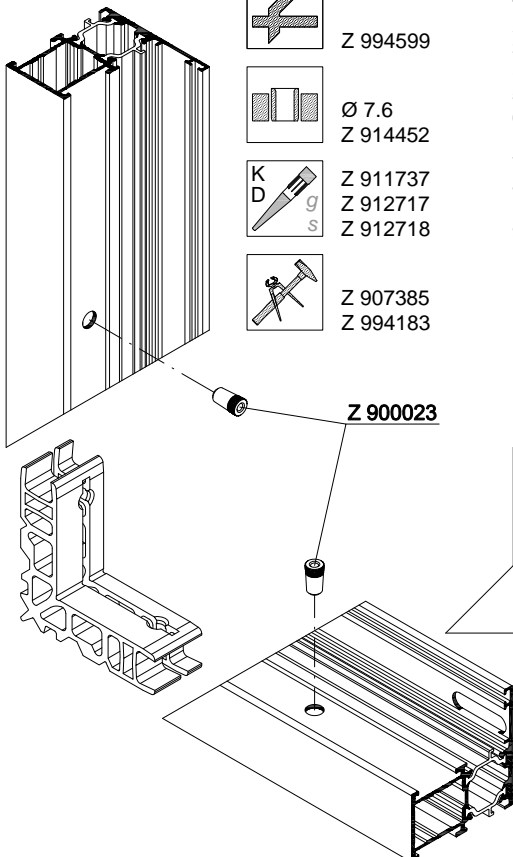

Bearbeitungsschritte

1. Profil sägen
2. Löcher stanzen / bohren
3. Schnittflächen versiegeln
4. Kleber einbringen
5. Eckverbinder einschieben
6. Rahmen fügen (erst Innen-, dann Außenkammer)
7. Aussteifungswinkel montieren
8. (77 XL, 77 L, 65 M Dichtstoff) (57 S Kleber) einbringen
9. (Mitteldichtungsecken montieren)

Processing steps

1. Saw the profile
2. Punch / drill the holes
3. Seal the cut surfaces
4. Insert the glue
5. Slide in the corner bracket
6. Join the frame (Internal chamber at first, then external)
7. Assemble the corner stabiliser
8. (77 XL, 77 L, 65 M sealing material) (57 S glue) in fit
9. (Assemble the centre seal gasket corners)

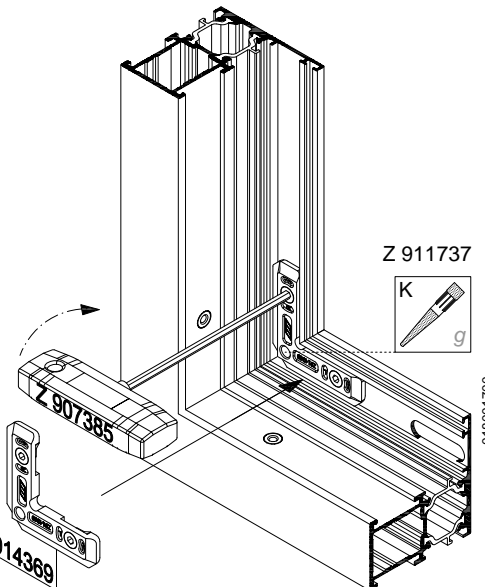
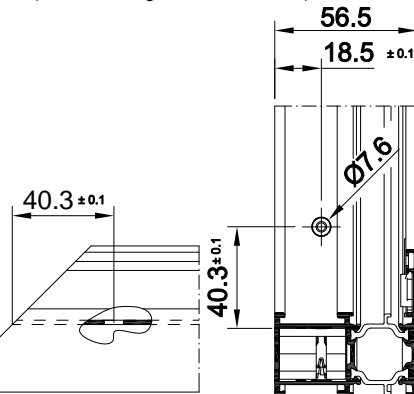

Lambda 77 L IF, 65 M IF



Z 996068



Ø 7.6
Z 914710
Z 914709



Z 911737
Z 912717
Z 912718



Z 994183

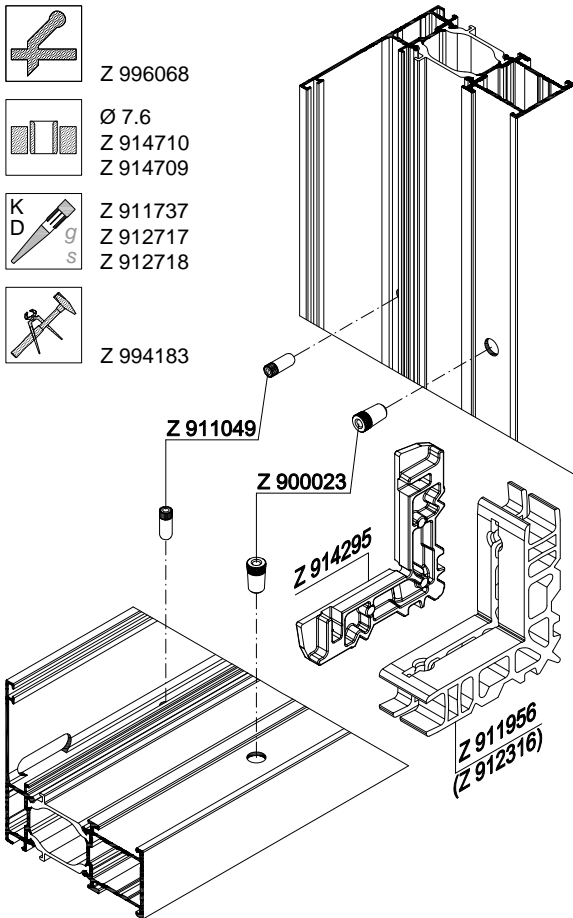

Z 912717
Z 912718

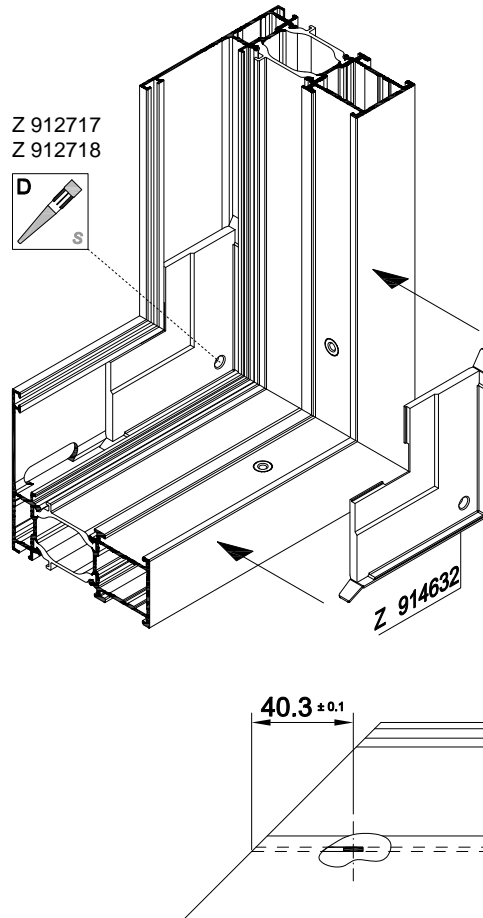

Bearbeitungsschritte

1. Profil sägen
2. Löcher stanzen / bohren
3. Schnittflächen versiegeln
4. Kleber einbringen
5. Eckverbinder einschieben
6. Rahmen fügen
(erst Innen-, dann Außenkammer)
7. Aussteifungswinkel montieren
8. (77 XL, 77 L, 65 M Dichtstoff)
(57 S Kleber) einbringen
9. (Mitteldichtungsecken montieren)

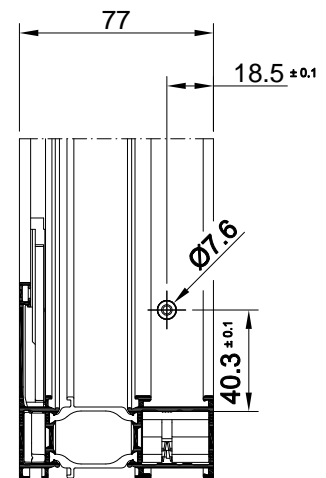

Z 996068



Ø 7.6
Z 914710
Z 914709



Z 911737
Z 912717
Z 912718



Z 994183

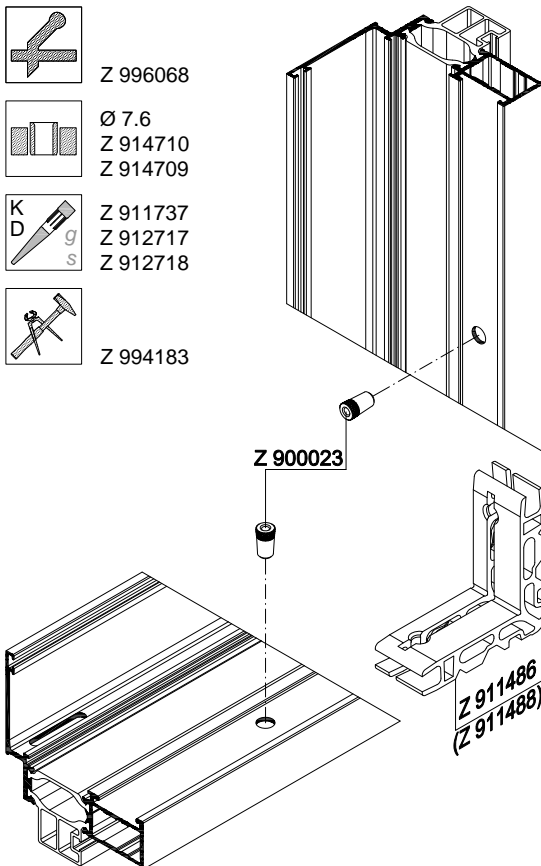

Z 911737

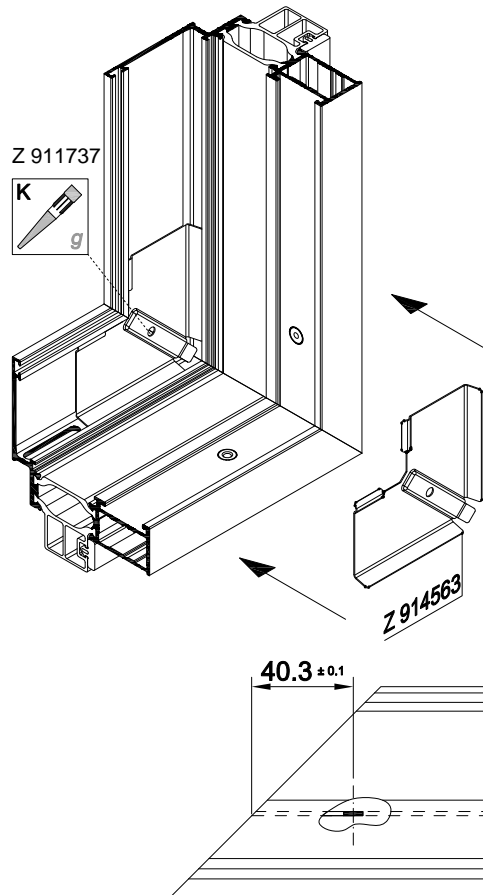

Processing steps

1. Saw the profile
2. Punch / drill the holes
3. Seal the cut surfaces
4. Insert the glue
5. Slide in the corner bracket
6. Join the frame
(Internal chamber at first, then external)
7. Assemble the corner stabiliser
8. (77 XL, 77 L, 65 M sealing material)
(57 S glue) in to fit
9. (Assemble the centre seal gasket corners)

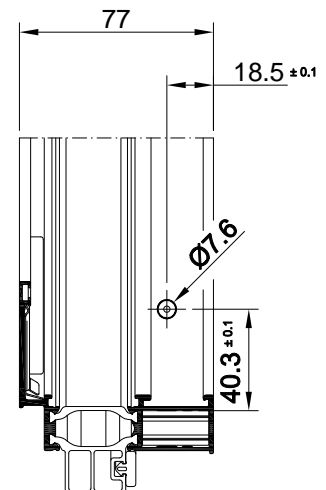

015001800

57 S

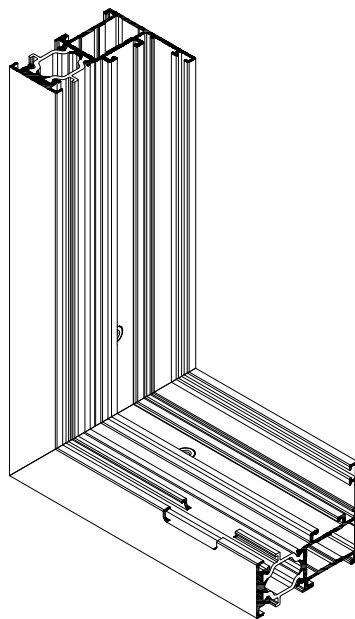
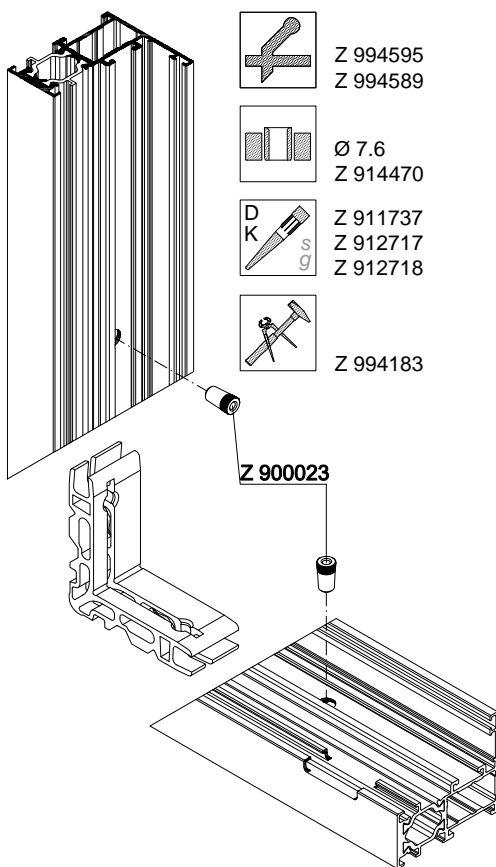

Bearbeitungsschritte

1. Profil sägen
2. Löcher stanzen / bohren
3. Schnittflächen versiegeln
4. Kleber einbringen
5. Eckverbinder einschieben
6. Rahmen fügen

Processing steps

1. Saw the profile
2. Punch / drill the holes
3. Seal the cut surfaces
4. Insert the glue
5. Slide in the corner bracket
6. Join the frame

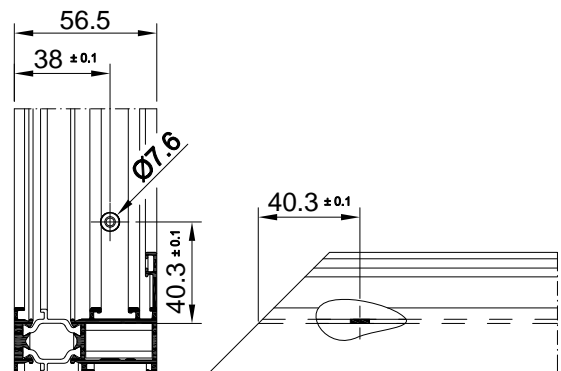

Lambda 77 L, 65 M, 57 S

verstellbare Eckverbinder
variable corner brackets

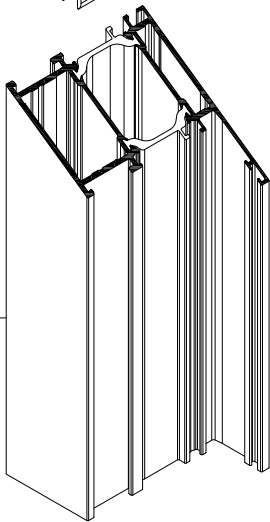
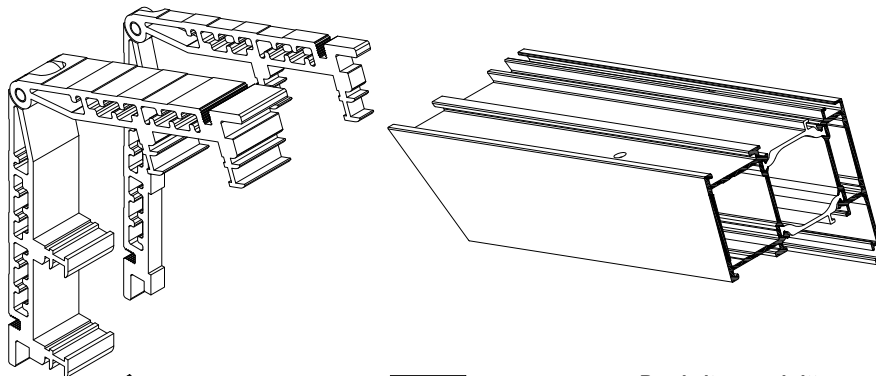

(B 80x000 / 300)
(B 80x010 / 310)
(B 80x020 / 320)
B 803030 / (B 806030)
(B 80x330)

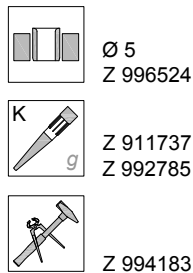

Bearbeitungsschritte

Wir empfehlen eine Probeecke anzufertigen

1. Profil sägen
2. Löcher bohren
3. Schnittflächen versiegeln
4. Kleber einbringen
5. Eckverbinder einschieben
6. Rahmen fügen
7. Bei spitzen Winkeln: zusätzlich von außen verspannen!
8. Erst belasten wenn Kleber ausgehärtet ist!

Processing steps

We recommend making a trial area

1. Saw the profile
2. Drill the holes
3. Seal the cut surfaces
4. Insert the glue
5. Slide in the corner bracket
6. Join the frame
7. At acute angles: in addition brace from the outside!
8. Only load when the glue has dried!

Anwendungsbereich von 45°-180°
(bei den Flügelprofilen im
Abhängigkeit der Öffnungsart und
Richtung)

Range of application
of 45°-180°
(the sash profiles in accordance of
opening type and direction)

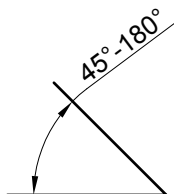

Bitte beachten Sie ausführbare
Winkel auch in Zusammenhang mit
dem verschiedenen Öffnungsarten
ergänzend auf den entsprechenden
Seiten im Kapitel Beschläge

Please regard executable
angles in context with different
opening types on the pages in the
fittings section as well

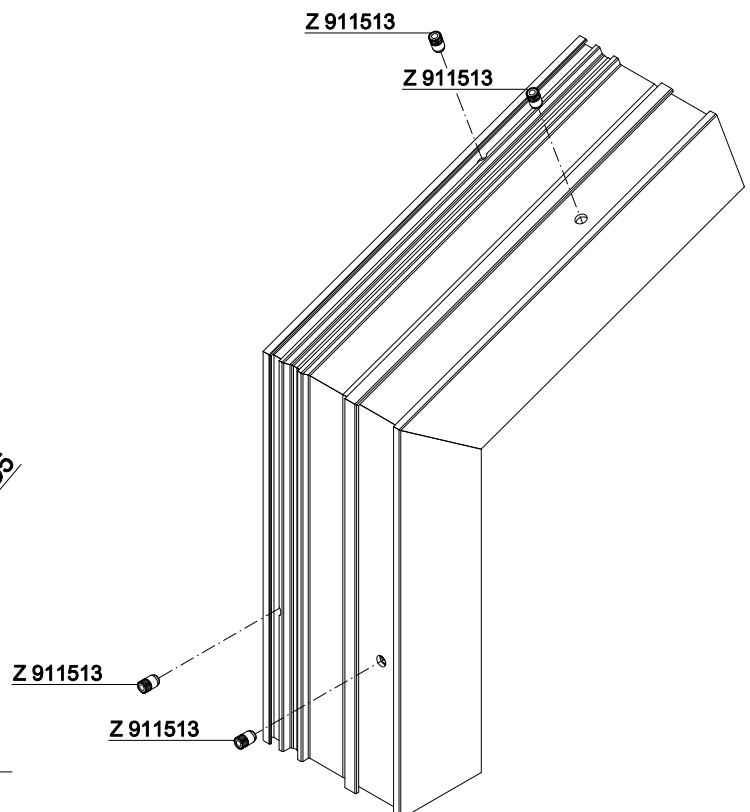
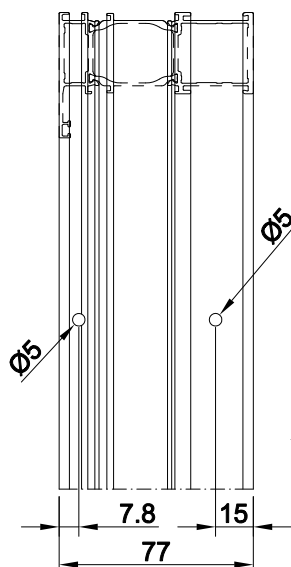

024010200

Lambda 77 XL, 77 L

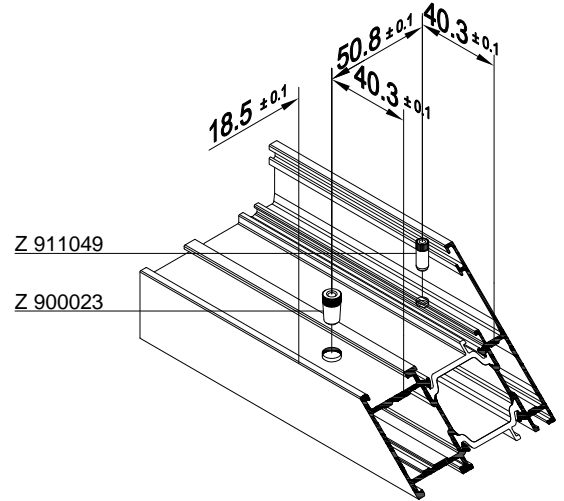
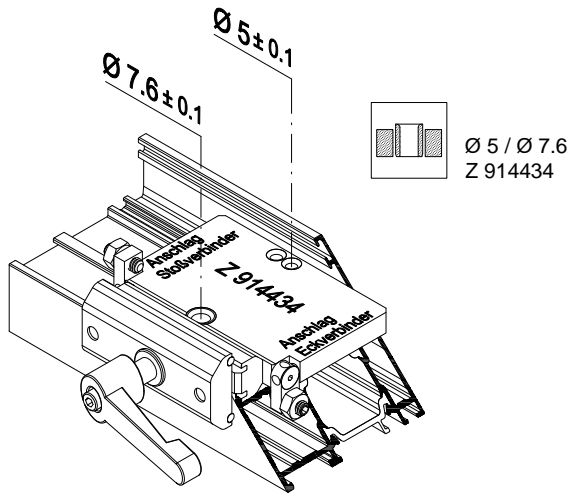

Lambda 65 M

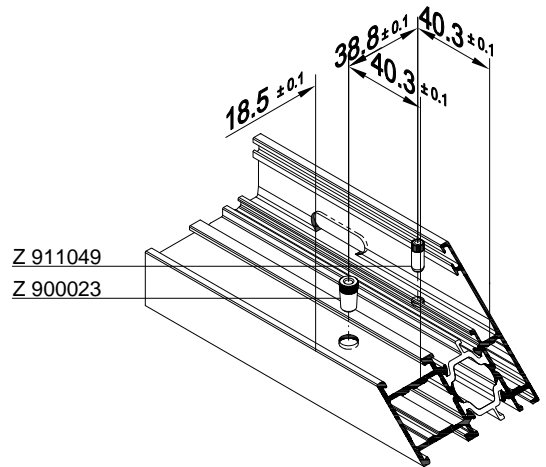
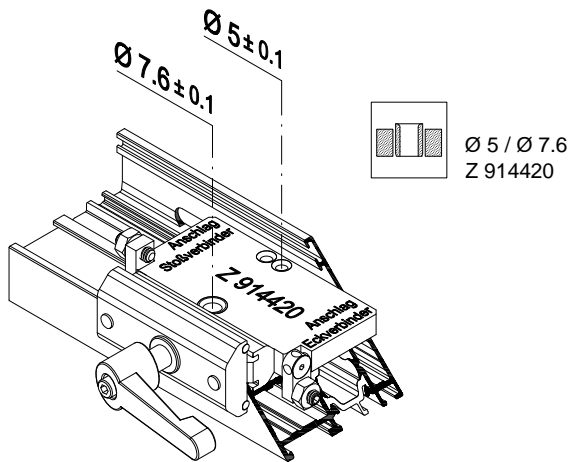

Lambda 57 S

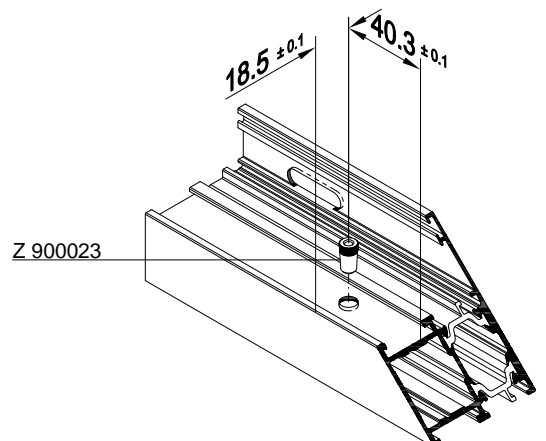
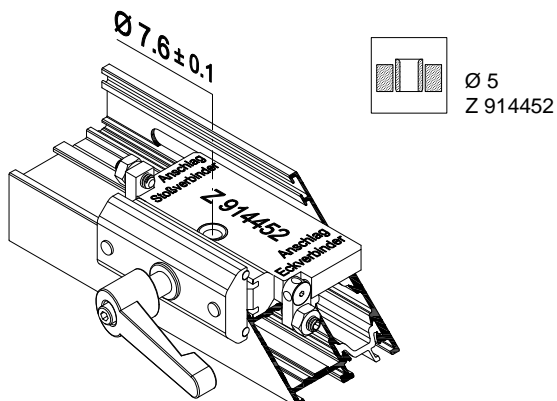

021002000

Lambda 77 L, 65 M, 57 S

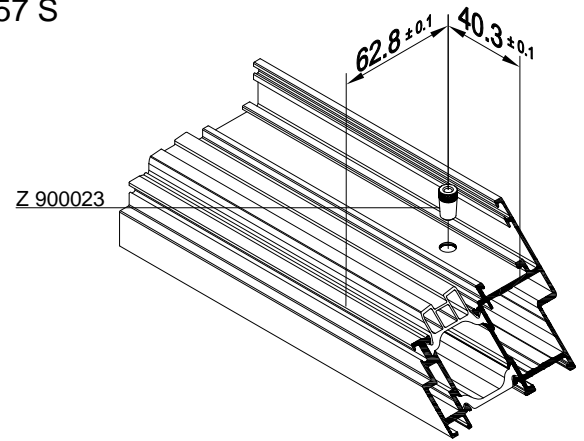
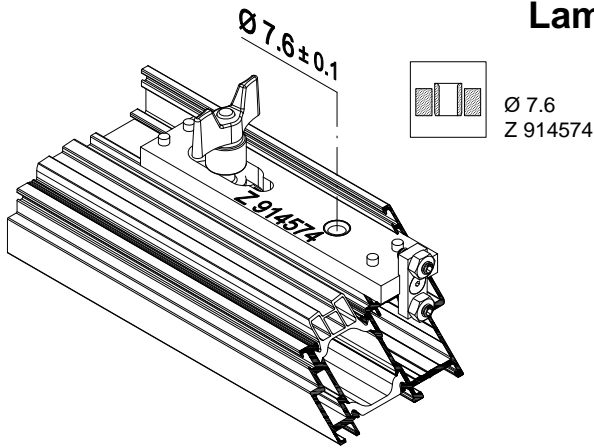

Lambda 77 L IF, 65 M IF

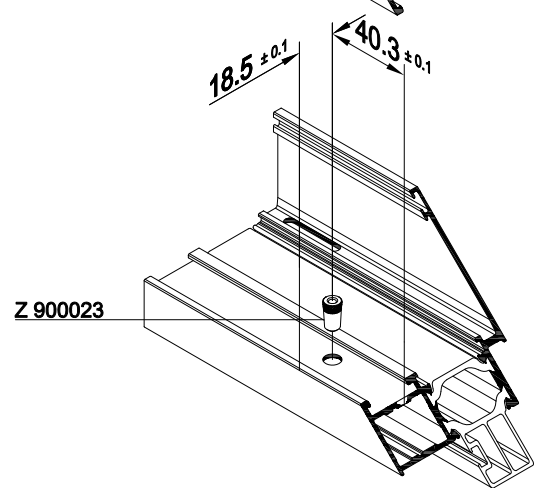
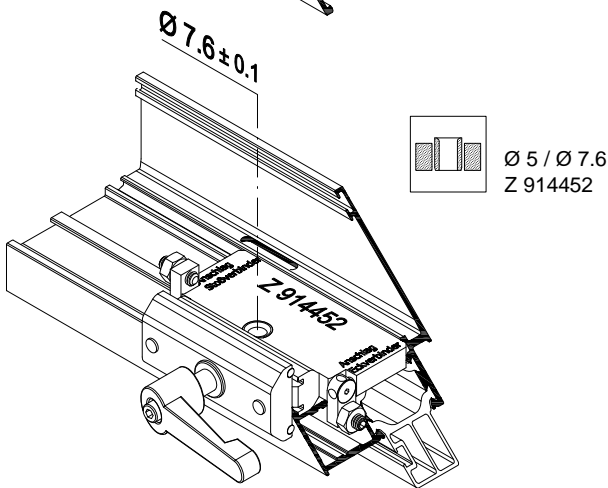
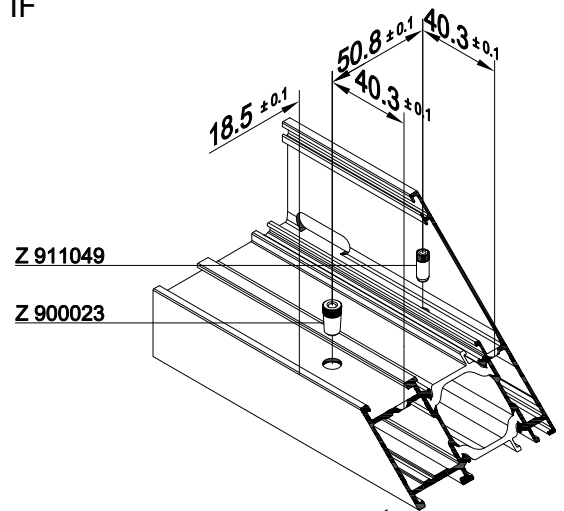
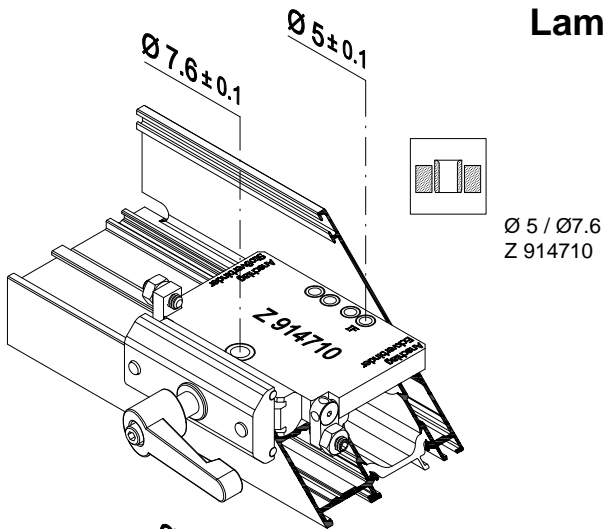

57 S

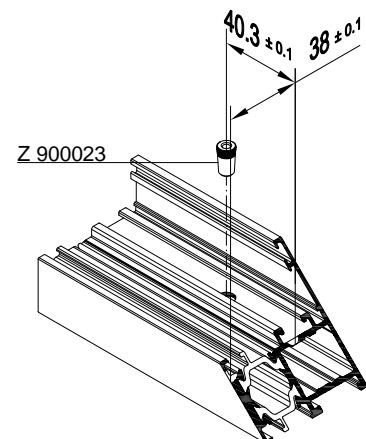
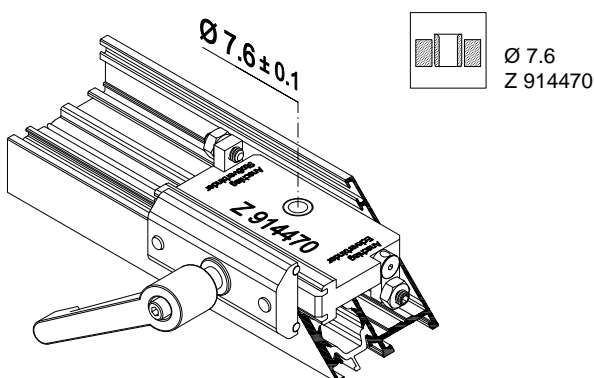

022002100

Lambda 77 XL, 77 L, 65 M, 57 S

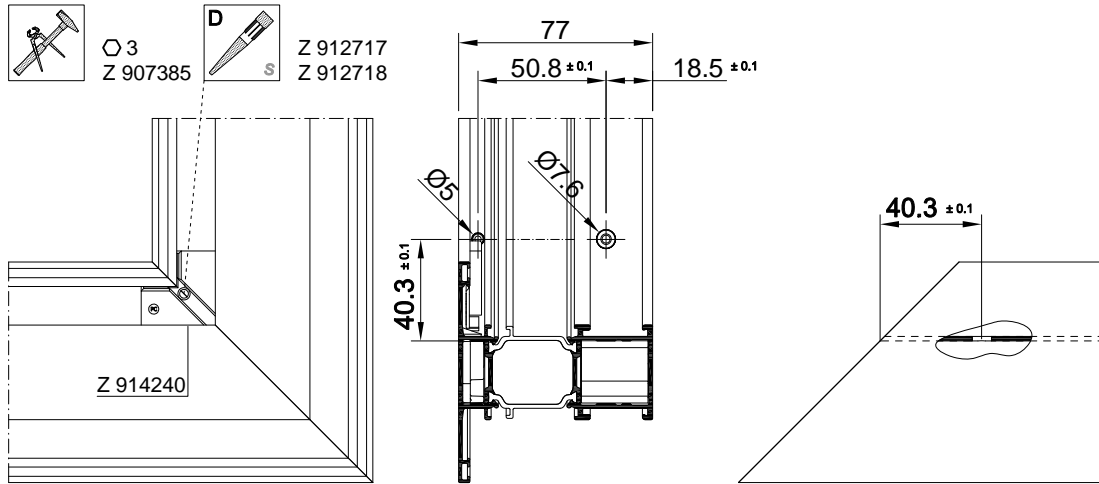

Für das Verbinden der Ecke der Querschnitte B 803360 und B 806360 mittels Eckenpresse sind eventuell angepasste Widerlager zu verwenden

Adjusted counter supports may be required for connecting the corner of sections B 803360 and B 806360 by means of the corner crimping machine

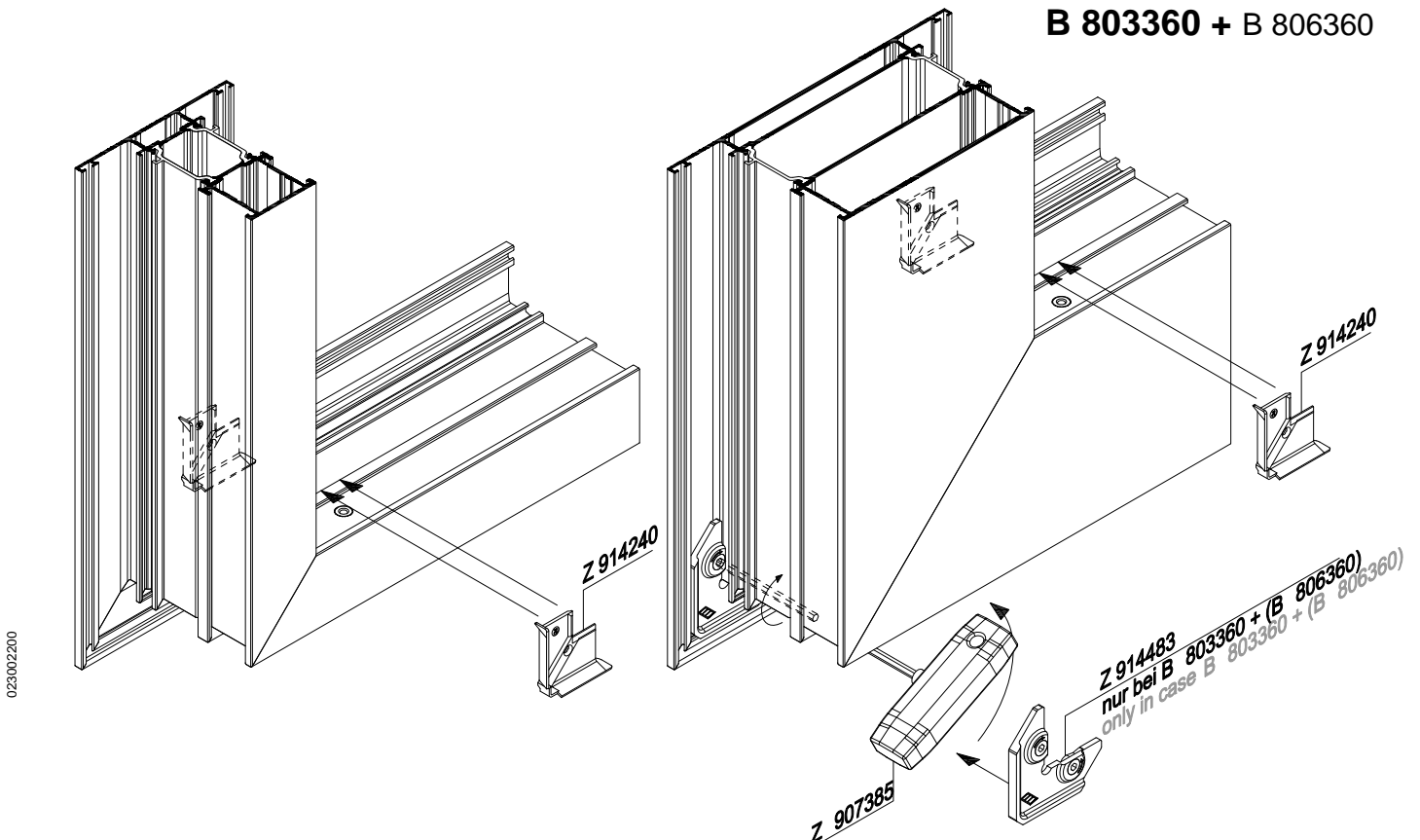

023002200