

**Windows/Doors
Europe****Contents Series 1.0 Door Contour****Page**

1. Contents	1
2. Construction features	2
3. Profile overview Static profile values	3
4. Profiles Connections	4 – 6
5. Glazing <ul style="list-style-type: none">• Glazing beads and glazing bead tables	1 – 2
6. Sections Details	1 – 6

Information on the Series*	Design features	<ul style="list-style-type: none"> • Various design possibilities for single-sash doors opening inwards, optionally with side lights with fixed glazing and/or fanlight • Geometry with sloping contour to the outside • Narrow elevation width, variable bottom rail heights, glass transoms • Max. sash weight 170 kg • Max. sash sizes: 1300 mm wide x 2200 mm high or 1100 mm wide x 2300 mm high • Three-chamber profiles, factory-mounted insulating composite • Can be coated at a later time • Numerous easy to mount wall connecting variants
	Modular system	<ul style="list-style-type: none"> • System components suitable for all the series: fittings, accessories, supplementary profiles, auxiliary accessories, tools • Series 1.0 Door, 1.0 Door Contour, A 72, RS C and BS C with identical optics: identical with regard to elevation width, gap dimension, gaskets and glass bite • Optionally transoms and bottom rail profiles with a profile depth of 80 mm, flush, or from series 1.0 Door with a profile depth of 72 mm, recessed
	Surfaces	<ul style="list-style-type: none"> • Anodisation in accordance with DIN 17611 • Plastic coating (wet paint, powder coating lacquer) in accordance with DIN 50939
	Connecting technology	<ul style="list-style-type: none"> • Corner bracket: crimpable, nailable, retro gluing after assembly • T-bracket for transom joints
	Elevation width	<ul style="list-style-type: none"> • Narrow elevation width of fixed and sash frame from 150 mm
	Profile depth	<ul style="list-style-type: none"> • Fixed frame: 80 mm, Sash: 80 mm
	Insulating zone	<ul style="list-style-type: none"> • Factory-mounted, glass fibre-reinforced polyamide strips • Profiles for fixed glazing in the space with PU foam
	Glazing	<ul style="list-style-type: none"> • Glass thickness between 18 mm and 53 mm depending on the sash profile • Optionally round or angular glazing beads
	Gaskets	<ul style="list-style-type: none"> • Glazing/rebate gasket: narrow elevation widths on inside and outside, gaskets can be drawn in continuously
	Insert elements	 <ul style="list-style-type: none"> • One sash • Opening in
	Fittings	<ul style="list-style-type: none"> • All common fitting variants • Surface-mounted hinges out of aluminium
	Safety constructions	<ul style="list-style-type: none"> • Escape door systems: emergency exit locks in accordance with EN 179 and panic locks in accordance with EN 1125, door hinges in accordance with EN 1935

Building physics*	Thermal insulation	DINV 4108-4 EN ISO 10077-2	$U_{f,BW} = 2.6 \text{ W/m}^2\text{K}$ U_f see SCT register
	Water tightness	EN 12208	Class 2A
	Air permeability	EN 12207	Class 1
	Resistance to wind load	DIN 18055	A

* All standards referred to herein, were valid at time of printing.

Valid test reports as well as technical information can be found in the download area of the site www.hueck-hartmann.com

Profile overview and static profile values for Series 1.0 Door Contour

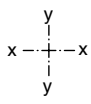
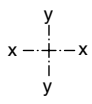
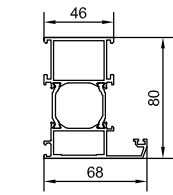
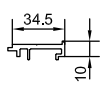
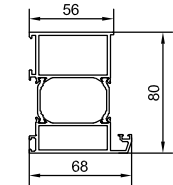
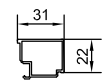
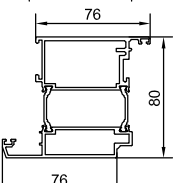
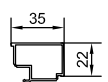
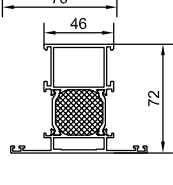
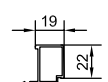
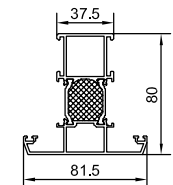
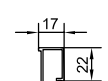
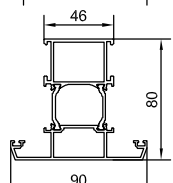
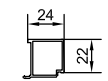
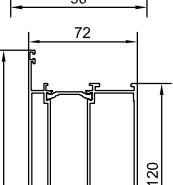
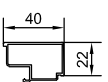
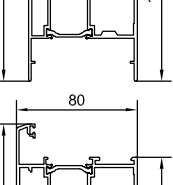
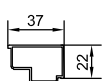
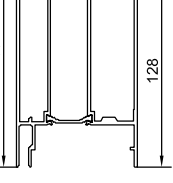
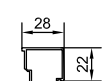
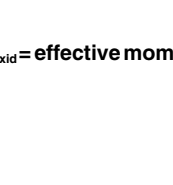
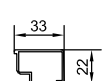
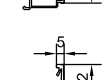
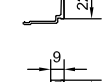
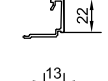
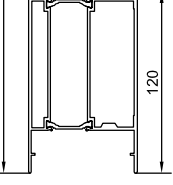
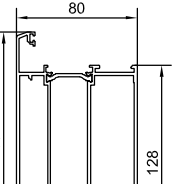
	Profile number	$I_{xid} [cm^4]$					External perimeter excluding insulating zone	Page 1.0 Door Contour		Profile number	$I_{xid} [cm^4]$					External perimeter excluding insulating zone	Page 1.0 Door Contour
		L [cm]	Distance between supports L [cm] in compliance with the guideline issued by the Institute of Building Technology								L [cm]	Distance between supports L [cm] in compliance with the guideline issued by the Institute of Building Technology					
		<200	from ≥ 200	from >250	from >300	from >400				<200		from ≥ 200	from >250	from >300	from >400		
	B521 152	-	-	-	-	-	391	4		P421 669	-	-	-	-	-	129	5
																	Glazing ↓
	B521 155	-	-	-	-	-	352	4		P594 053	-	-	-	-	-	122	1
	B521 155	-	-	-	-	-	352	4		P594 055	-	-	-	-	-	130	1
	B521 254	-	-	-	-	-	436	4		P594 057	-	-	-	-	-	109	1
	B521 254	-	-	-	-	-	436	4		P594 058	-	-	-	-	-	109	1
	B510 301	30	35	38	40	43	382	5		P594 059	-	-	-	-	-	110	1
	B510 301	30	35	38	40	43	382	5		P594 061	-	-	-	-	-	140	1
	B510 340	33	38	42	44	47	458	5		P594 062	-	-	-	-	-	134	1
	B510 340	33	38	42	44	47	458	5		P594 064	-	-	-	-	-	116	1
	B521 352	-	-	-	-	-	477	5		P594 065	-	-	-	-	-	126	1
										P494 071	-	-	-	-	-	121	1
										P494 072	-	-	-	-	-	131	1
										P494 073	-	-	-	-	-	139	1
	B521 500	-	-	-	-	-	524	6									
	B521 501	-	-	-	-	-	634	6									

I_{xid} = effective moment of inertia

I_{xid} = effective moment of inertia

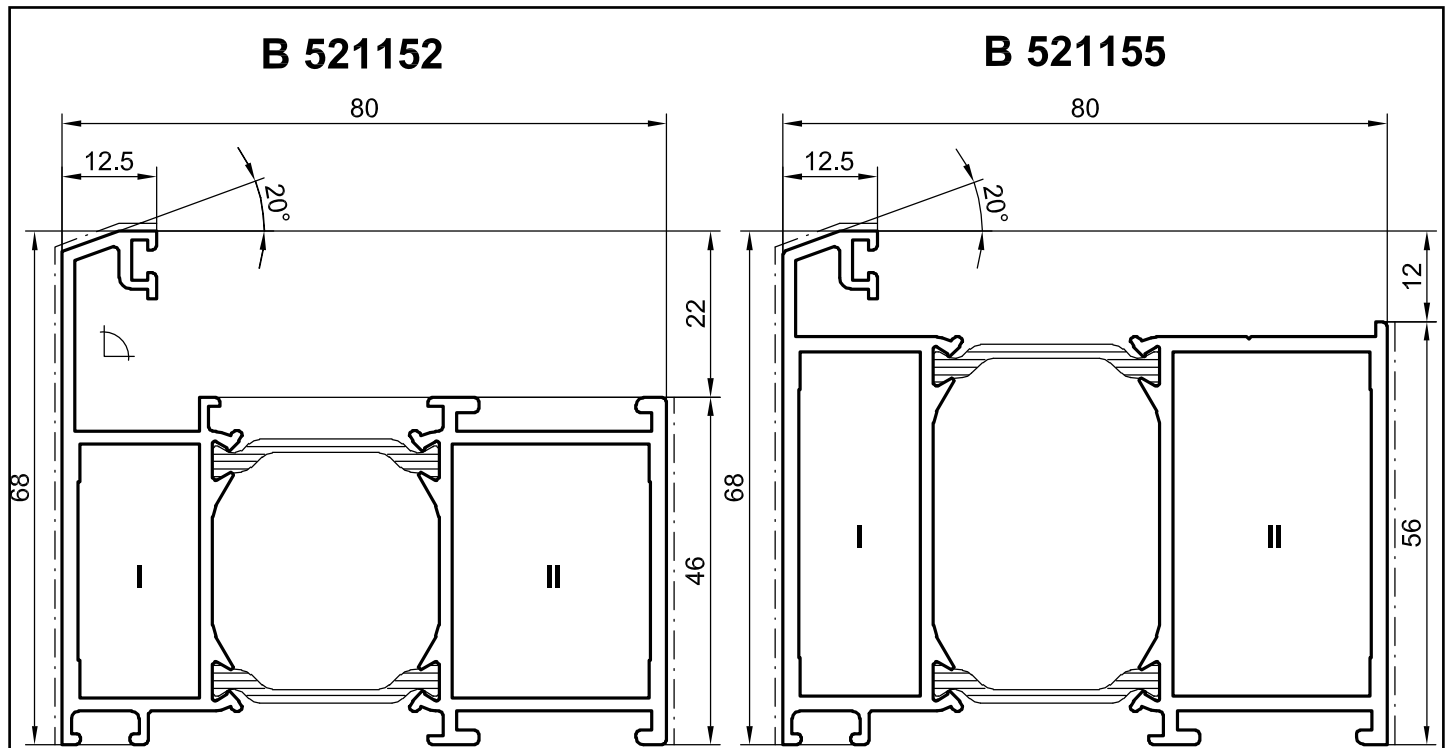
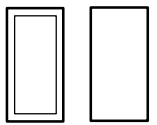

B 521254

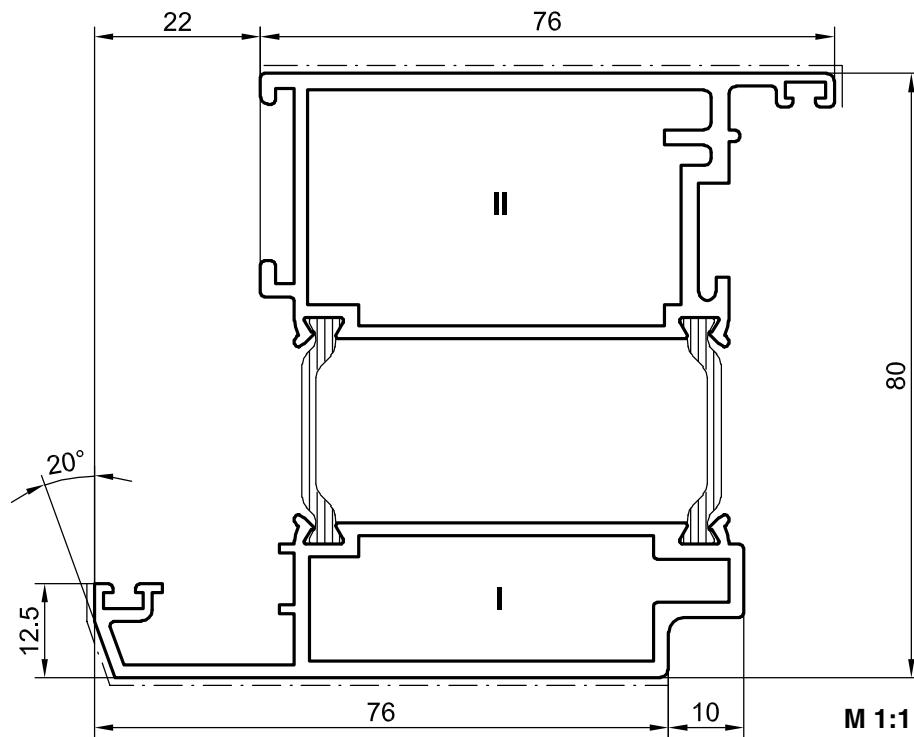

crimpable available retro gluing after assembly	Outer chamber I					Inner chamber II					
B 521 152	Z 911 182	Z 912 049	Z 911 062	2 x Z 911 049	Z 911 187	-	Z 911 120	-	Z 911 062	2 x Z 900 023	Z 903 233
B 521 155	Z 911 182	Z 912 177	Z 912 182	2 x Z 911 049	Z 911 187	-	Z 912 176	-	Z 912 182	4 x Z 900 024	Z 903 233
B 521 254	Z 911 182	Z 912 050	Z 911 271	2 x Z 911 049	Z 911 187	-	Z 994 042	-	Z 911 271	4 x Z 900 024	Z 903 233

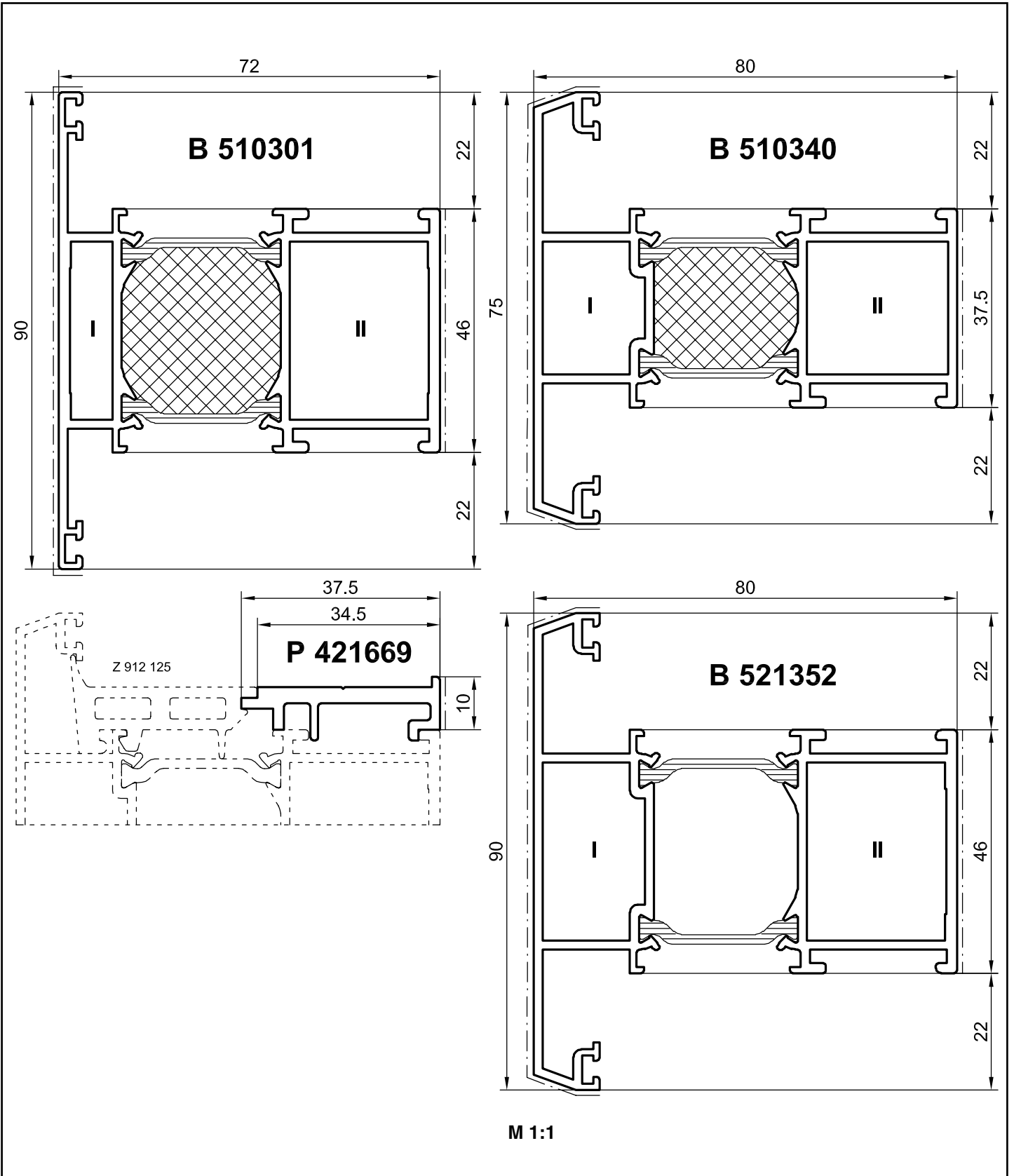
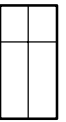

M 1:1

	Outer chamber I					Inner chamber II					
B 521 352	-	Z 912 180	Z 911 050	Z 911 049	Z 911 187	-	Z 911 125	-	Z 911 063	Z 911 049	Z 903 233
B 510 301	-	Z 912 148	Z 911 050	2 x Z 911 049	Z 911 187	-	Z 911 125	-	Z 911 063	2 x Z 911 049	Z 903 233
B 510 340	-	Z 912 181	-	2 x Z 911 049	Z 911 187	-	Z 911 031	-	Z 911 063	2 x Z 911 049	Z 903 233

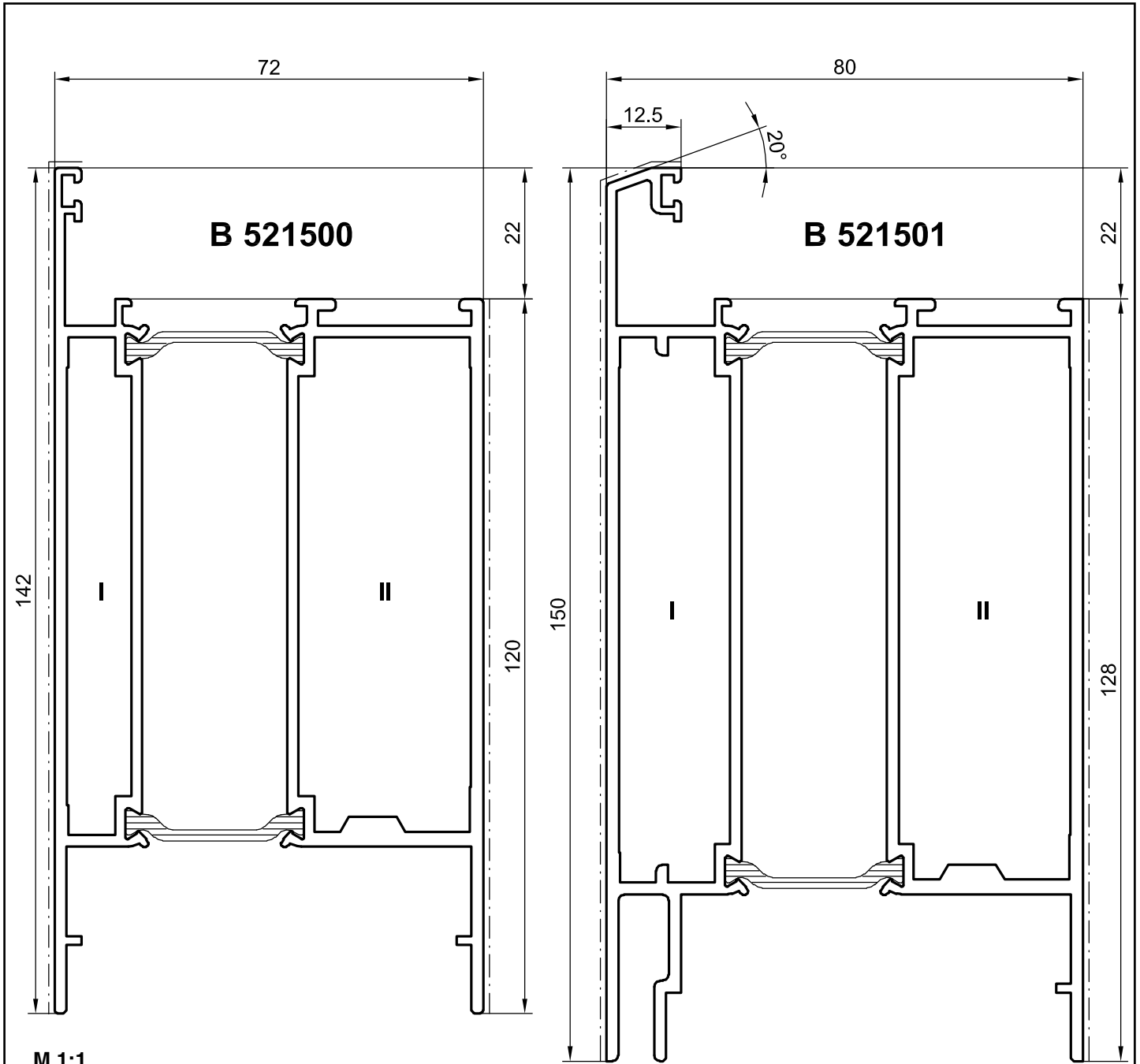

M 1:1

Outer chamber I						Inner chamber II					
B 521 500	-	Z 912 147	Z 911 050	2 x Z 911 049	Z 911 187	-	Z 911 197	-	Z 911 063 Z 911 451	2 x Z 911 049	Z 903 233
B 521 501	-	Z 912 179	Z 911 050	Z 911 049	Z 911 187	-	Z 912 178	-	Z 911 063 Z 911 451	Z 911 049	Z 903 233

P 494071

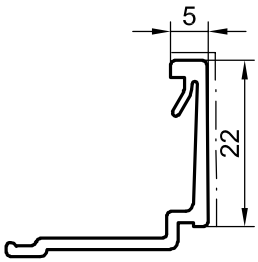

P 494072

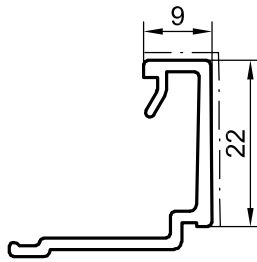

P 494073

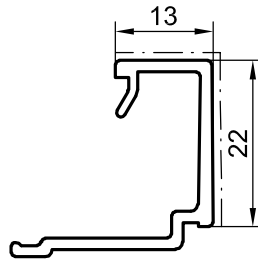

P 594058

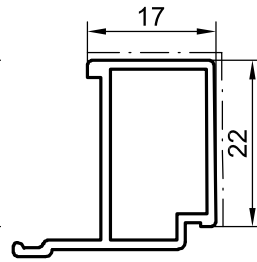

P 594057

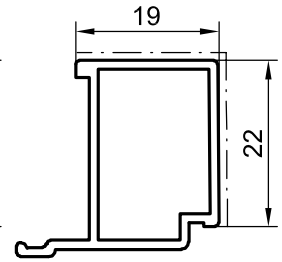

P 594059

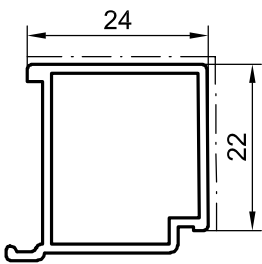

P 594064

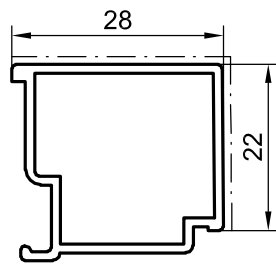

P 594053

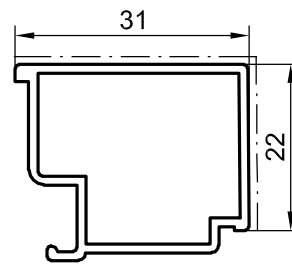

P 594065

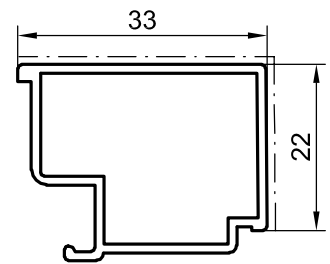

P 594055

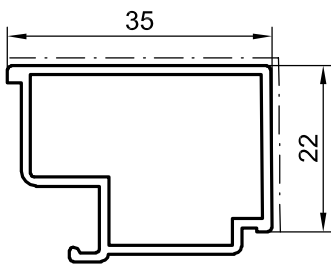

P 594062

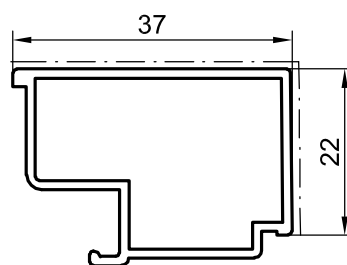

P 594061

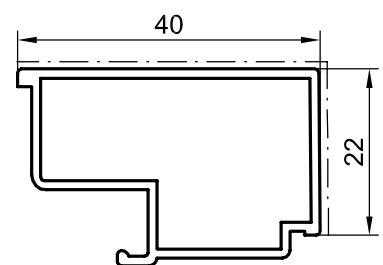

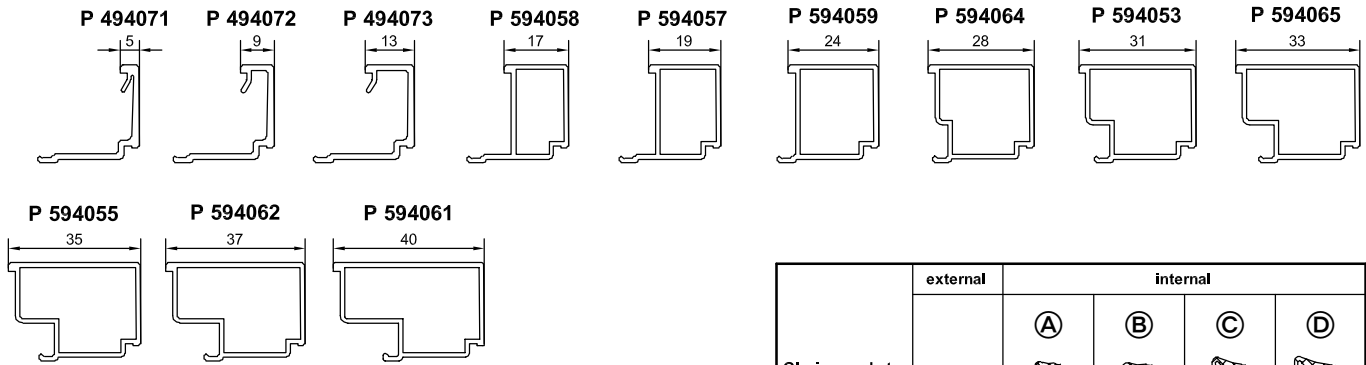

	external	internal			
		(A)	(B)	(C)	(D)
Glazing gaskets					
Article no.	Z 911 081	Z 911 079	Z 911 108	Z 911 078	Z 911 080
Gap dimension in mm	4	4.0 - 7.0	5.5 - 8.0	6.5 - 9.0	7.5 - 10.5

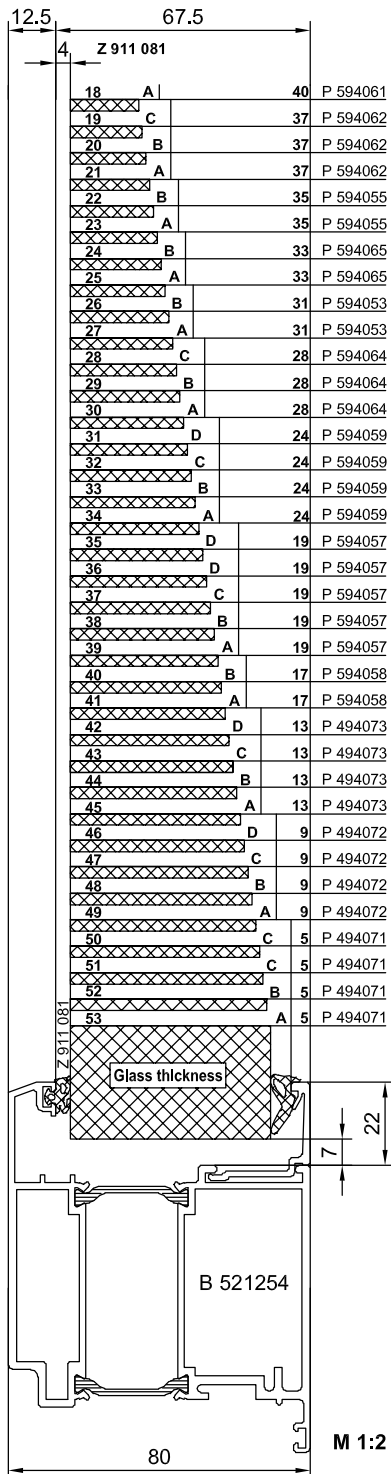

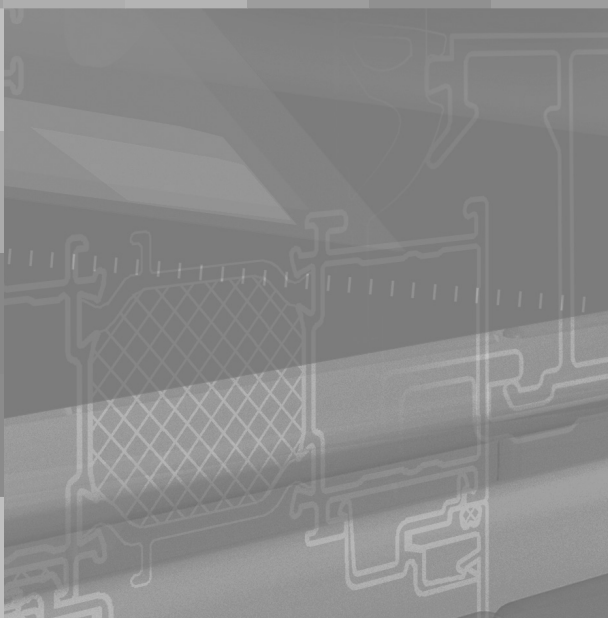

Sections HUECK Series 1.0 Door Contour

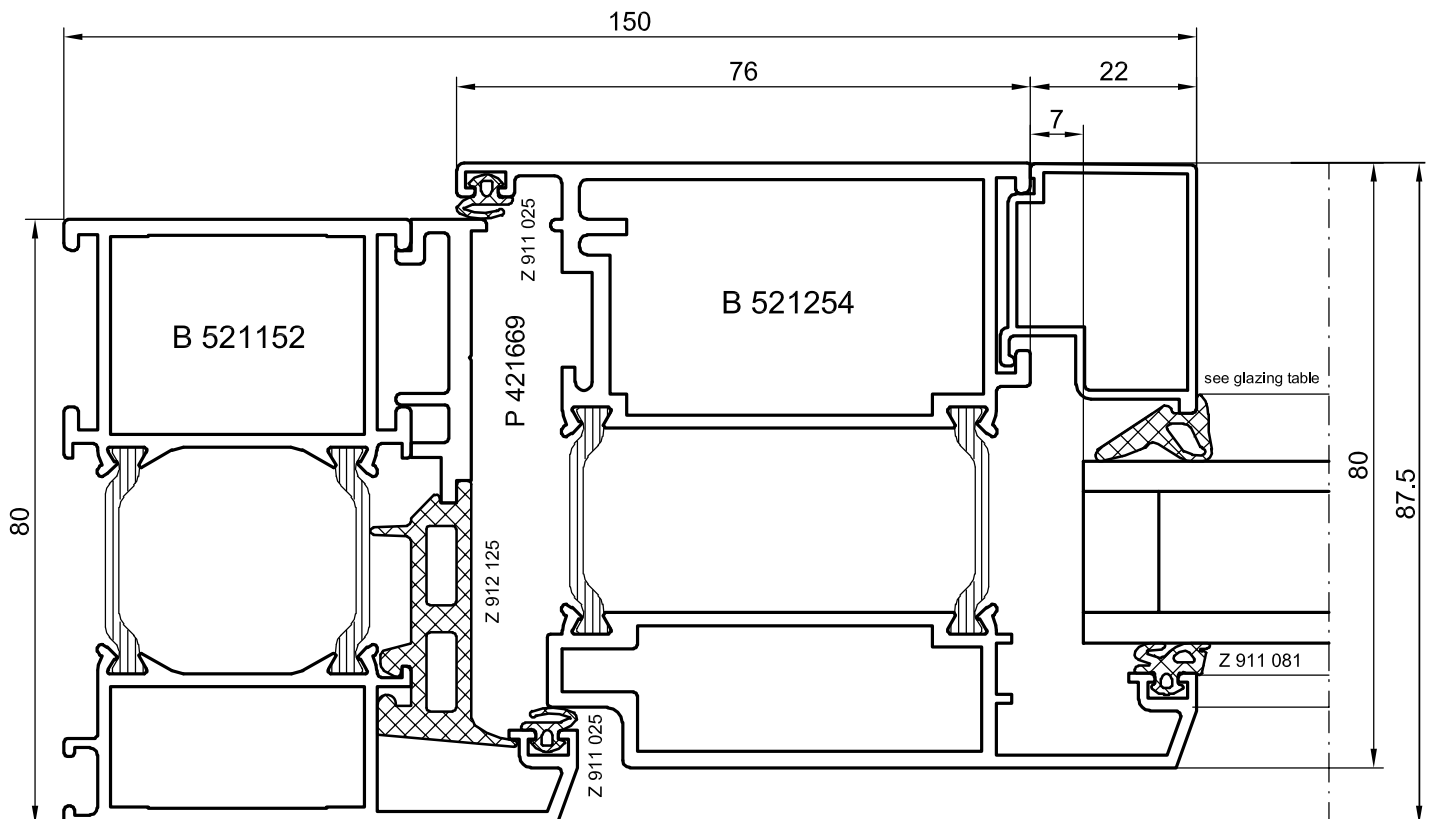
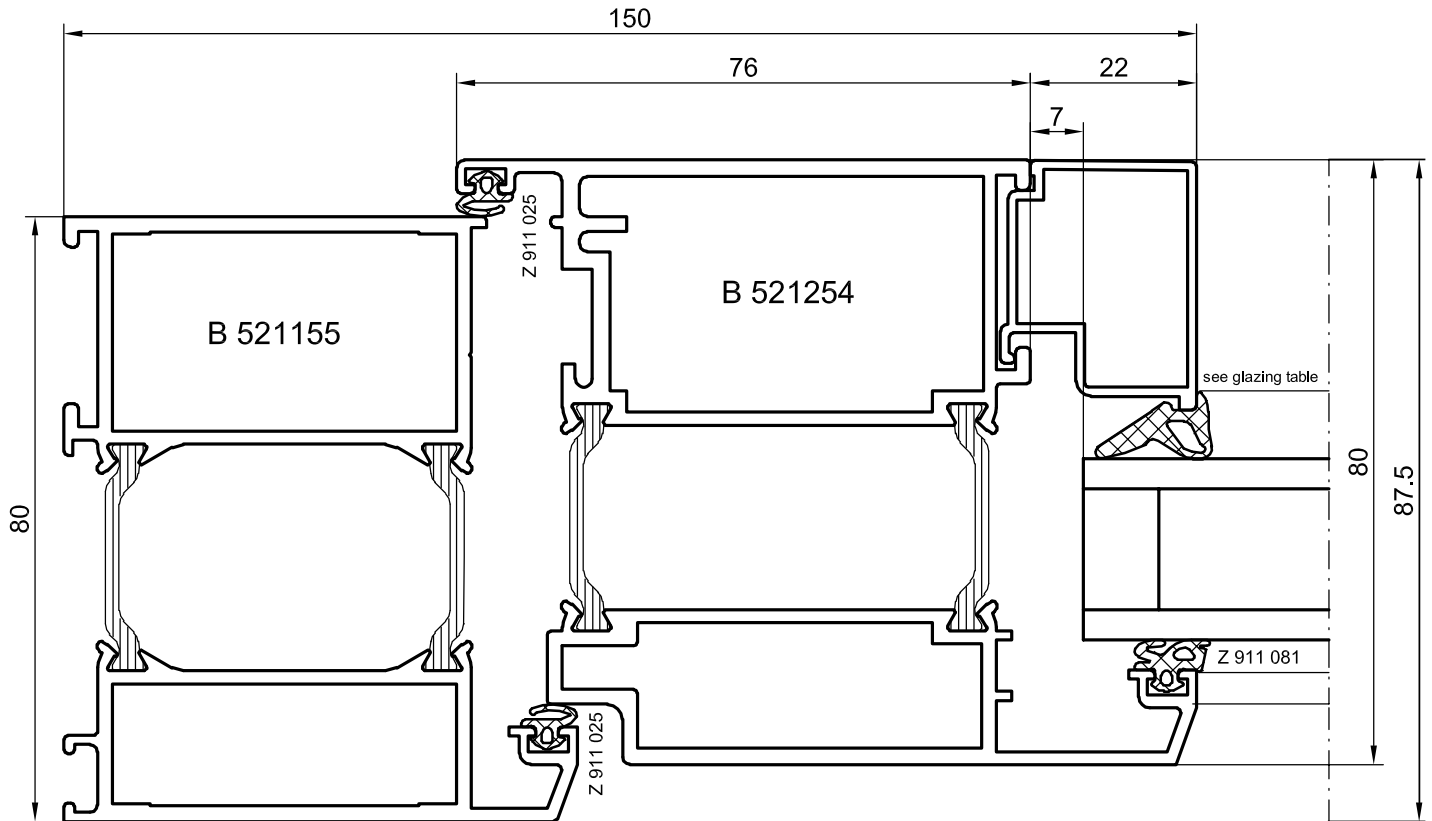
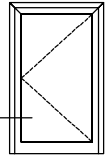

M 1:1

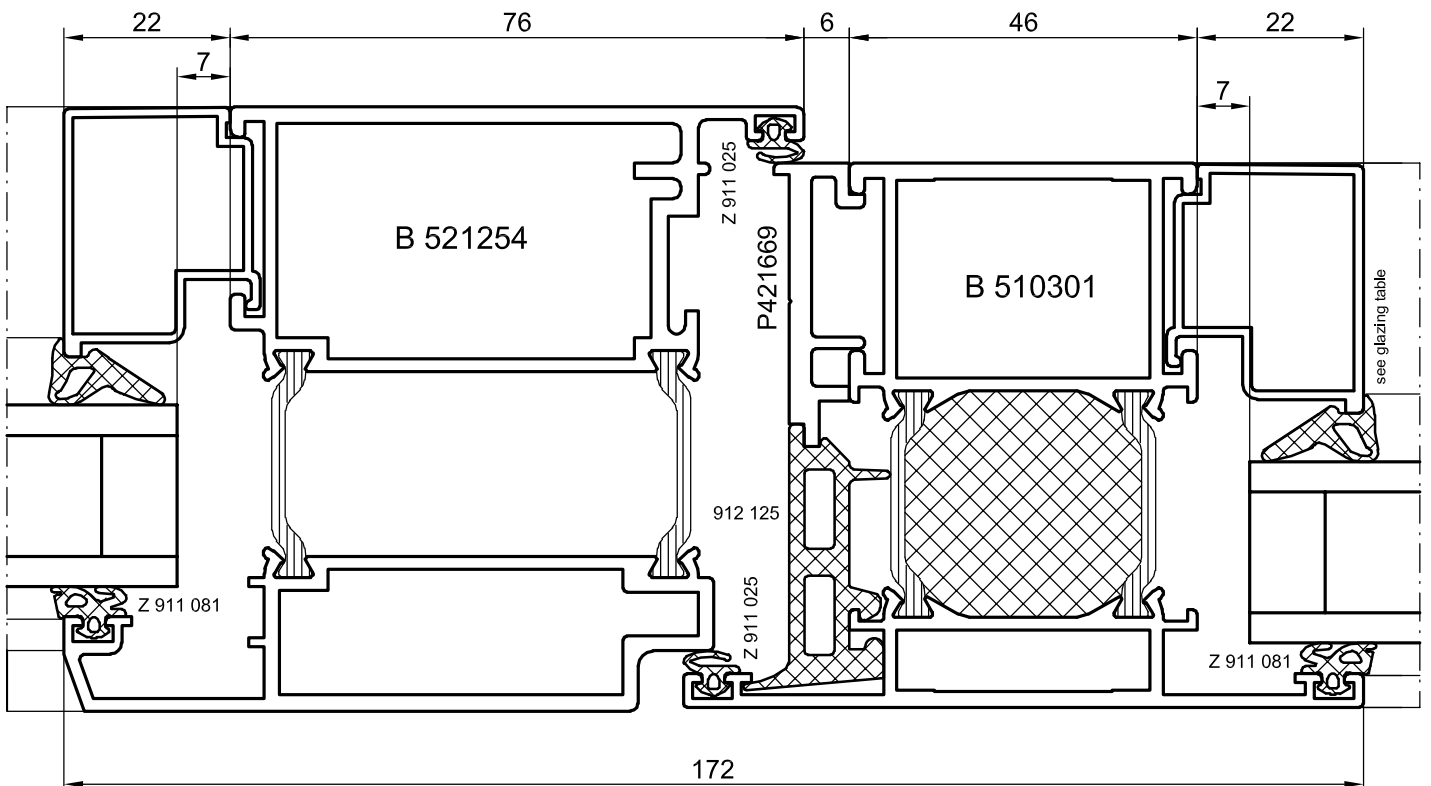
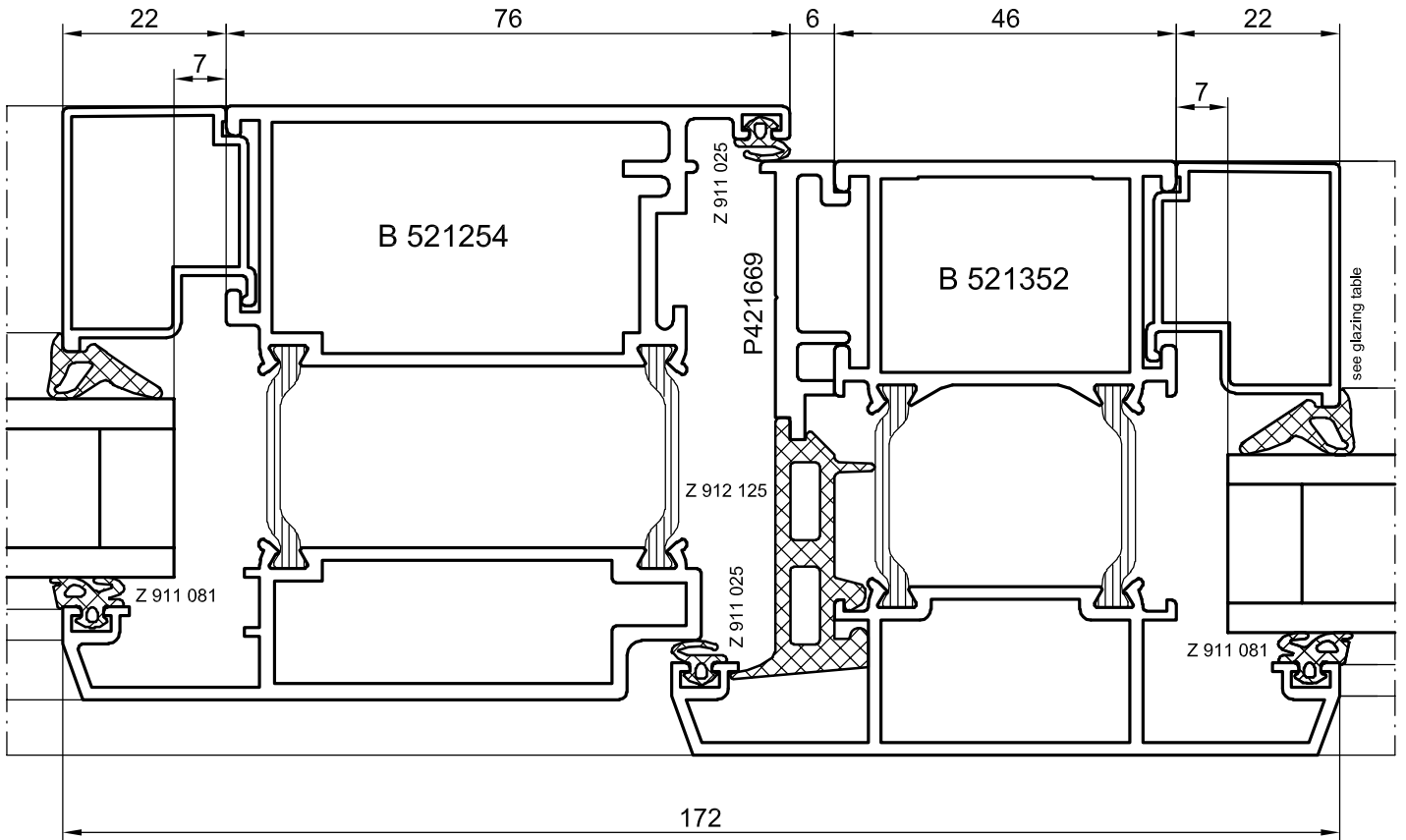
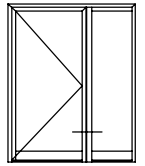

M 1:1

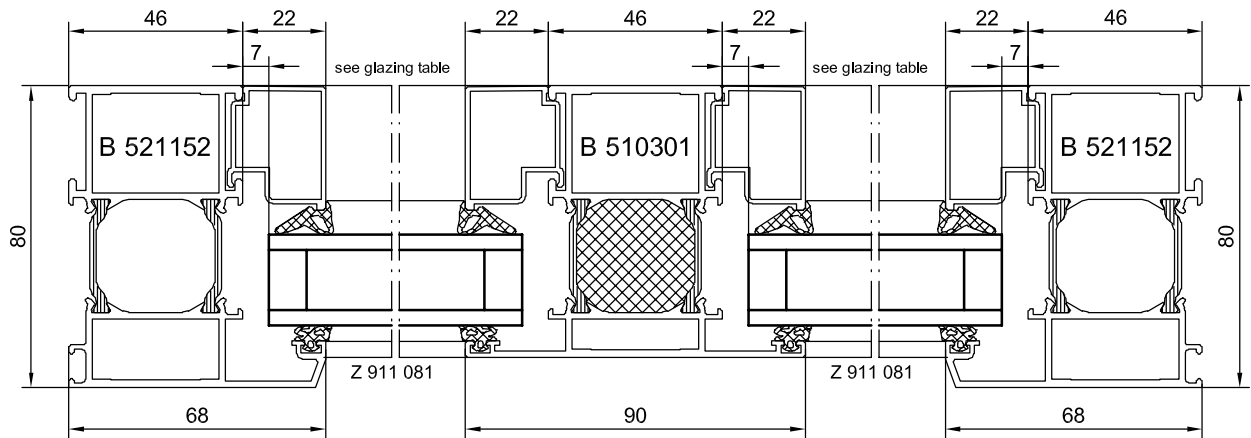
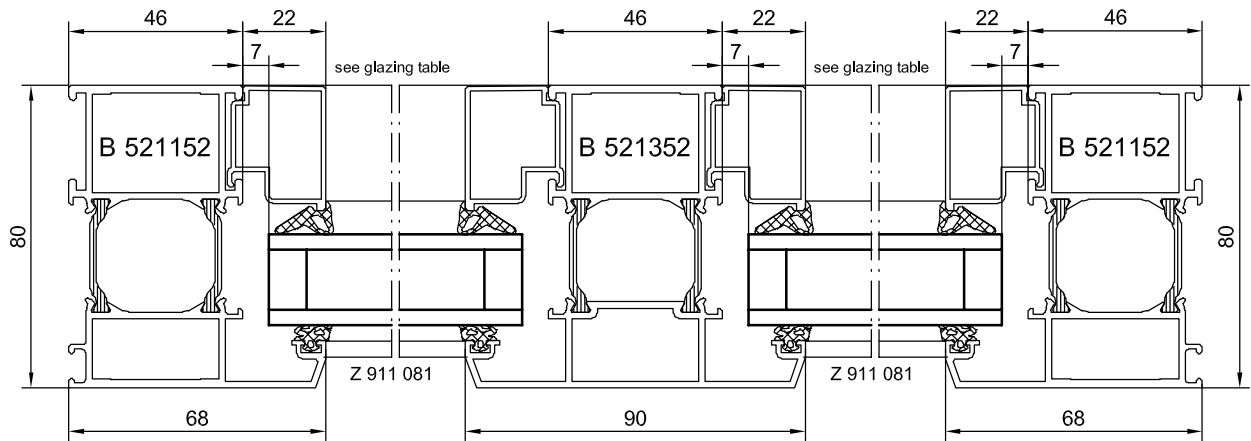

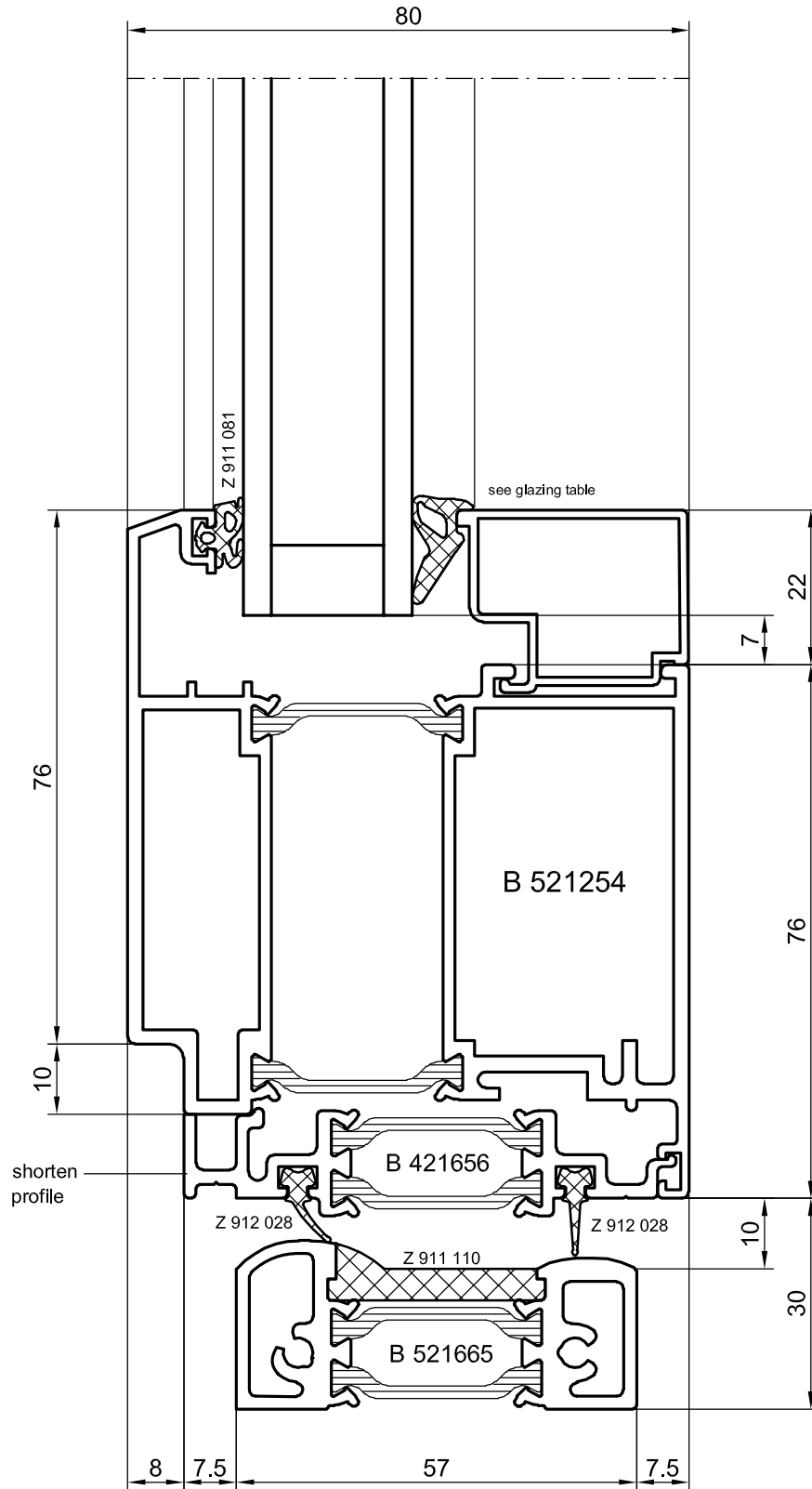

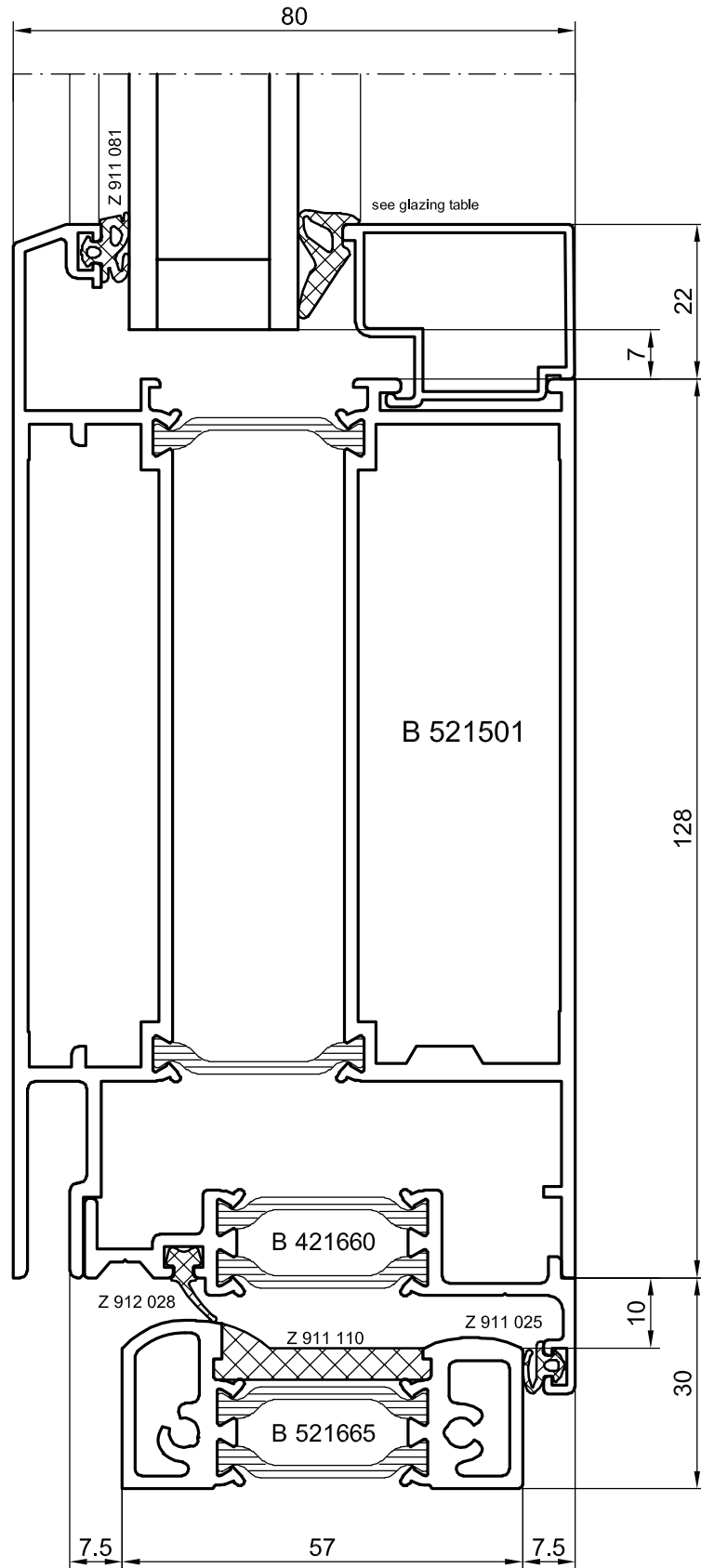
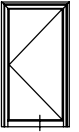

M 1:1