

## Corner connection

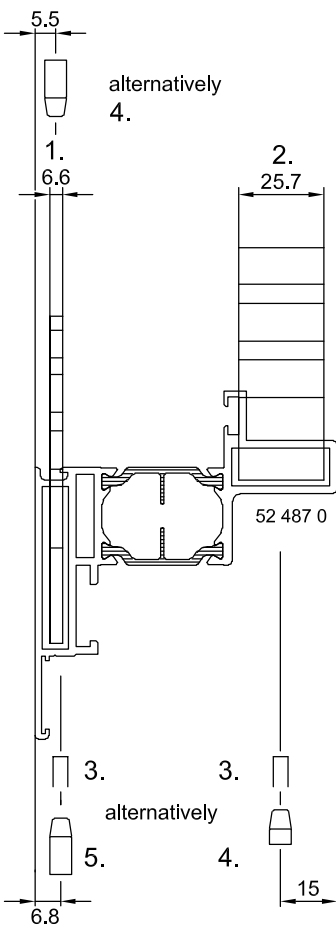

1.  
inside

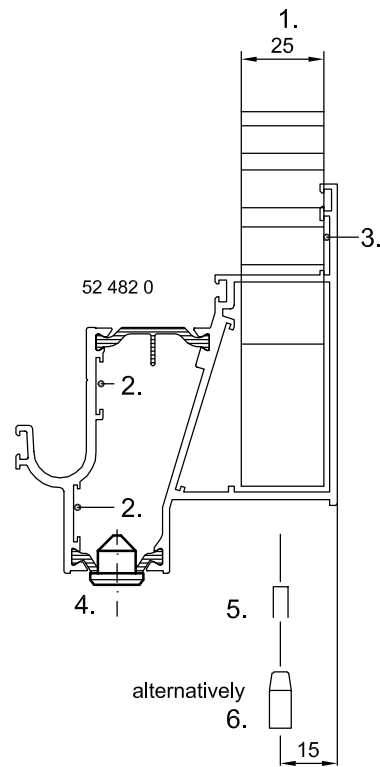
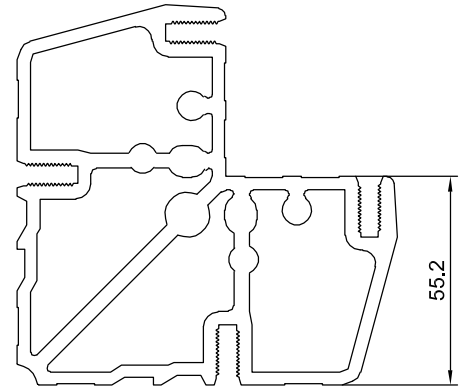

pos.	article number	designation	pegging	pressing
			quantity	quantity
1.	<b>53 892 0</b>	internal corner bracket	1	1
2.	<b>26 013 0</b>	mitre angle	2	2
3.	<b>26 300 0</b>	mitre angle	1	1
4.	<b>24 129 0</b>	tension element	1	1
5.		crimping knife and counter support		cf. next page
6.	<b>24 391 0</b>	tapered pin	2	
7.	<b>22 103 0</b>	drilling jig, diameter 5.8/14		

1.  
outside

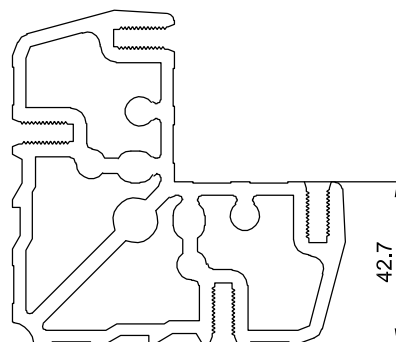

2.  
inside

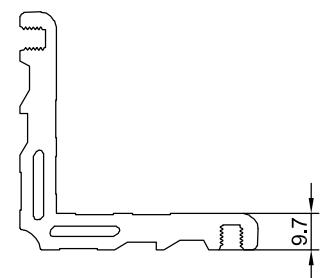

pos.	article number	designation	pegging	pressing
			quantity	quantity
1.	<b>53 894 0</b>	external corner bracket	1	1
2.	<b>53 893 0</b>	internal corner bracket	1	1
3.		crimping knife and counter support		cf. next page
4.	<b>24 390 0</b>	tapered pin	2	
5.	<b>24 391 0</b>	tapered pin	2	
6.	<b>22 104 0</b>	drilling jig, diameter 5.8		

**Extrusion dies for corner connections**

PRESSTA-EISELE GmbH, Bergstraße 9, 56859 Bullay

Please place your order directly with the manufacturer

Type of machine P V 7 / P V 8			P V 10	
Profile no.	Crimping knife	Counter support	Crimping knife	Counter support
52 482 0	105-10-30-20	B709	01/000000100	208/0901410
52 487 0	123-7-30-D78,5	B711-1	04/584179070	208/0900331

Type of machine PRESSTA 1000/1800			PRESSTA 2000/DEV 2000	
Profile no.	Crimping knife	Counter support	Crimping knife	Counter support
52 482 0	01/000000100	B709	01/000000100	Standard
52 487 0	04/584179070	B711-1	04/584179070	Standard

ELUMATEC Eugen Lutz GmbH & Co, Pinacherstr. 61 75417 Mühlacker-Lomersheim

Please place your order directly with the manufacturer

Profile no.	Lower crimping knife	Upper crimping knife	Profile no.	Lower crimping knife	Upper crimping knife
52 482 0	on request	on request	52 487 0	on request	on request

LOTH GmbH & Co. KG, Postfach 1265, 66273 Sulzbach

Please place your order directly with the manufacturer

Profile no.	Lower crimping knife	Upper crimping knife	Counter supports
52 482 0	on request	on request	on request
52 487 0	on request	on request	on request

RAPID Maschinenbau GmbH, Tübinger Straße 2, 72131 Ofterdingen

Please place your order directly with the manufacturer

Profile no.	Crimping knife	Counter support	Profile no.	Crimping knife	Counter support
52 482 0	on request	on request	52 487 0	on request	on request

Comment concerning all manufacturers of extrusion dies:  
Check the technical condition of older types of machines prior to processing RMG 1-profiles and/or contact the manufacturer.