

Series 1.0 VF50
Façade design
thermally insulated

Information on the series*	Design features	<ul style="list-style-type: none"> • Design for vertical, slanting, level or polygonal curtain walls, sloping and cupola roofs • Optimised profile geometry with regard to area and static parameters • Smoothed-off edges at the mullion and transom profile with a radius of 2 mm • Various cover profiles
	Modular system	<ul style="list-style-type: none"> • System components suitable for all the series: fittings, accessories, supplementary profiles, auxiliary accessories, tools
	Surfaces	<ul style="list-style-type: none"> • Anodisation in accordance with DIN 17611 • Plastic coating (wet paint, powder coating lacquer) in accordance with DIN 50939
	Connecting technology	<ul style="list-style-type: none"> • Mullion-transom connection approved by the building supervisory authority
	Elevation width	<ul style="list-style-type: none"> • Mullion, transom and cover profiles with an elevation width of 50 mm in various profile geometries
	Profile depth	<ul style="list-style-type: none"> • Between 32 and 196 mm in accordance with static requirements
	Insulating zone	<ul style="list-style-type: none"> • Spacer profiles made of glass fibre-reinforced polypropylene • Foamed insulating profiles for increased thermal insulation
	Glazing	<ul style="list-style-type: none"> • Glass thickness between 16 and 52 mm • External glazing with EPDM sealing profiles and screwed aluminium pressure plate profile • Internal sealing profiles optionally as vulcanised frames or as metre-length material • Continuous uniform gasket thickness on the room side
	Gaskets	<ul style="list-style-type: none"> • Vulcanised shaped gasket pieces used in the transom connection area • Optionally single-piece or two-piece EPDM gaskets as external gasket • Weather-independent, can be inserted on site without sealing material
	Vapour pressure equalisation	<ul style="list-style-type: none"> • Large-volume drainage grooves located in the mullion on both sides • Overlapping drainage principle through transom notching • Concealed openings in the pressure plate profiles of the mullions • Shaped ventilation piece
	Insert elements	<ul style="list-style-type: none"> • Series 1.0: Window, window IF, door, top-hung projecting out window • Series 72 E: Window, integrated window, door, top-hung projecting out window • Skylight windows: Series VF 50/VF 60, Series 85 E
Safety constructions	<ul style="list-style-type: none"> • Burglar protection WK1, WK2, WK3 in accordance with ENV 1627 • Fire protection: BSC-VF60 in accordance with EN 1364-1, fire-resistance class EI30 or EW30 respectively 	

Building physics*	Thermal insulation	With spacer profiles made of polypropylene	DINV 4108-4 ENISO 10077-2	U_f 1.7 W/m²K – 3.5 W/m²K U _f see SCT register
		With foamed insulating profiles for increased thermal insulation	DINV 4108-4 ENISO 10077-2	U_f 1.0 W/m²K – 1.4 W/m²K U _f see SCT register
	Water tightness	Static class	EN 12154	RE 1200
		Dynamic class	ENV 13050	250 Pa / 750 Pa
	Air permeability		EN 12152	Class AE
	Resistance to wind load		EN 13116	Test load 2000 Pa, safety 3000 Pa
	Sound reduction		EN ISO 140-3	R_{D,R} up to 44 dB

* All standards referred to herein, were valid at time of printing.

Valid test reports as well as technical information can be found in the download area of the site www.hueck-hartmann.com

Series 1.0 VF 50

Façade design, thermally-insulated
as a mullion-transom construction

Elevation width: 50 mm

U_f between 1.08 W/m²K and 3.19 W/m²K (cf. register SCT)

Elements of the series:

1.0 Window

1.0 IF Window

1.0 Door

1.0 Projecting out window

1.0 VF50/VF60 rooflight, supplementary element

1.0 VF50/VF60 rooflight, insert element

72E Window

72E Integrated window

72E Door

72E Projecting out window

72E Floating window

85E Flush rooflight

System: Inlet transom

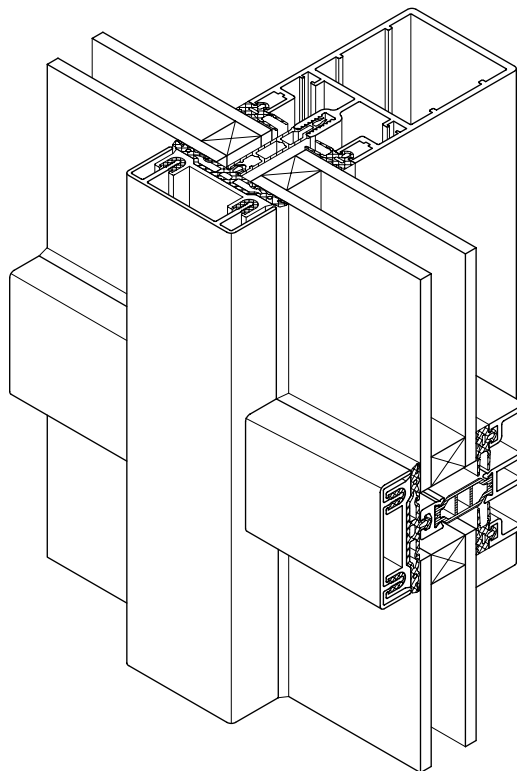

**System: Deepened transom
with spacer profile**

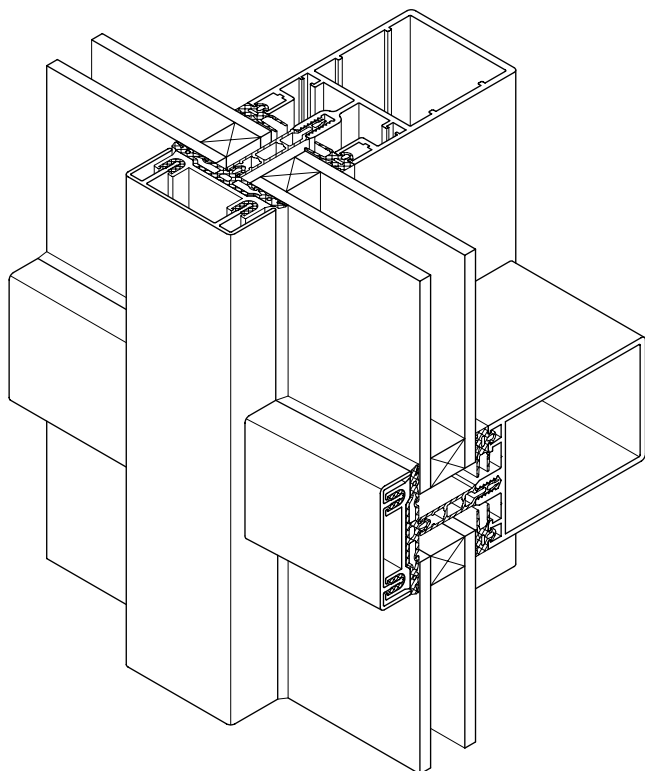

**System: Deepened transom
with insulating profile**

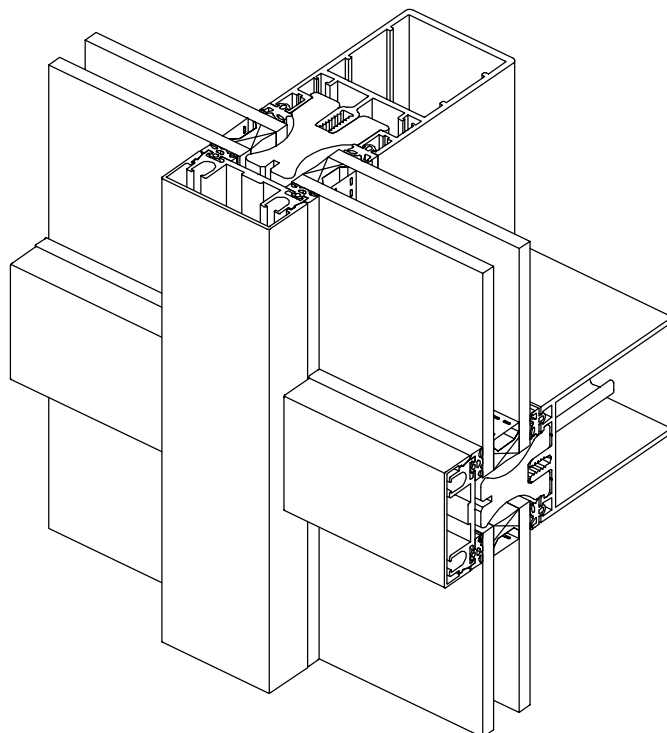

Further variants with:

- spacing or insulating profiles
- pressure plate and cover profiles
- internal and external glazing gaskets
cf. page 17 and details from page 21